

MRG OIL AND GAS CE PAD

EE-SAR- 000-001-1

Lighting Mitigation Plan

Prepared by: David Nowicki, PE



1401 Blake St | Denver, Colorado 80202

Main 303-623-3345 | Toll Free 1-855-CAMPOS1 (226-7671) | Fax 303-904-0570

www.camposepc.com

No.	Description	Approval	Date
0	Issued As Attachment To The Permit	DN	08/03/2022
	Issued As Attachment To The Permit – Sound Walls Added	DN	9/26/2022

Note: Only values affected by the addition of the sound walls have been updated and indicated accordingly. Items not affected by the addition of the sound wall have not been revised and remain as initially released.

				
EE-SAR- 000-001-1 Lighting Mitigation Plan				
Client:	MRG Oil and Gas	Rev	Date	Description
Project:	CE Pad	1	09/26/22	Issued As Attachment To The Permit

Table of Contents

Table of Contents 1

A. Summary..... 2

B. Codes, Standards, Practices, and Software 3

C. Methodology 3

D. Best Management Practices 4

E. Lighting Impacts up to 1 mile..... 5

F. Lumens per Square Feet Calculations..... 8

G. Attachments 13



				
REPORT				
Client:	MRG Oil and Gas	Rev	Date	Description
Project:	CE Well Pad	1	9/26/22	Issued As Attachment To The Permit

A. Summary

Campos EPC, LLC (CEPC) was retained by Ardor Environmental to develop a lighting mitigation plan for MRG Oil and Gas CE pad that included preproduction and production phases of the site development. This report demonstrates compliance with the Colorado Oil and Gas Conservation Commission (COGCC) Rule 424, City of Loveland Division 18.09.02 Lighting Ordinances, Larimer County Code of Ordinances 4.10 Exterior Lighting, and Larimer County Code of Ordinances 11.3.13 Lighting and Visual Impacts.

Lighting impacts are summarized below.

Category - Lumens Per Square Foot	Calculated Value	Limit
Preproduction Drilling Phase (lm/ft ²)	11.9 lm/ft ²	≤ 12 lm/ft ²
Preproduction Completions Phase (lm/ft ²)	9.9 lm/ft ²	≤ 12 lm/ft ²
Production (lm/ft ²)	0.1 lm/ft ²	≤ 5 lm/ft ²

1

1

Category - Impacts on RBU within 1 mile	Calculated Value	Limit
Preproduction Drilling Maximum (lux)	0.1 lux	≤ 4.0 lux
Preproduction Completions Maximum (lux)	0.1 lux	≤ 4.0 lux
Production (lux)	≤ 0.1 lux	≤ 4.0 lux

All calculated values are within the prescribed limits.



				
REPORT				
Client:	MRG Oil and Gas	Rev	Date	Description
Project:	CE Well Pad	1	9/26/22	Issued As Attachment To The Permit

B. Codes, Standards, Practices, and Software

The following was relied upon for this report.

Colorado Oil and Gas Conservation Commission (COGCC) Rule 424 Lighting

Lamier County, Land Use Code Article 4.10 Exterior Lighting

Lamier County, Land Use Code Article 11.0 Oil and Gas Facilities, 11.3.13 Lighting and Visual Impacts

City of Loveland Ordinances, Division 18.09.02

DIALux evo Version 10.1

AGI 32 Photometric Toolbox Version 2.9

C. Methodology

For lighting impacts on Residential Building Units (RBU) within 1 mile, a three-dimensional lighting model was developed which encompasses the surrounding area of the site topology for 1 mile. RBU locations were identified within the 1-mile radius of the site and a vertical wall simulated. The lighting model simulated impacts on the residential building units up to 1 mile for the preproduction and production phases. The calculated values were summarized and compared to regulatory limits.

For compliance for lumens per hardscape, exterior fixtures light output information was gathered that indicates light fixture output in lumens. Exterior lights light output was summarized based on type, lumen output, and number of lights for the site based on the phase. The total site lumen output was ratioed to the site hardscape and compared to the regulatory limits.

The models developed for the preproduction phases are based on current lighting systems for drilling and completions. Due to the nature of rental equipment and availability, portable light towers are subject to change and the models are based on current available units.

The following assumptions were relied upon for this report.

- The height of the drill rig is 155 feet.
- Zero degrees (0°) represents a luminaire facing directly downward.
- Intermittent sources of lights for alarms lights are not included in this analysis.
- The quantity, placement and calculated values shown represent an estimated upper limit based on the model and lighting analysis.



				
REPORT				
Client:	MRG Oil and Gas	Rev	Date	Description
Project:	CE Well Pad	1	9/26/22	Issued As Attachment To The Permit

D. Best Management Practices

The following best management practices are used during the preproduction phases.

- Lights are angled away from surrounding off site buildings
- Lighting for preproduction has been reduced to provide a minimum acceptable level for safe operation.
- Lights are switched off when not required.
- Lights are directed to task areas only.
- Light masts are automatically switched on and off based on a lighting sensor.

The following best management practices are used for the production phase.

- Lighting levels do not exceed 10-foot candles.
- Type H lights are specified with IDA Dark Sky approved fixture with visor.
- Type H lights fixtures are mounted at a height of 12 feet above grade.
- Lights are to be provided with a photocell sensor which automatically turns on when at dusk and turns off during daylight hours.



				
REPORT				
Client:	MRG Oil and Gas	Rev	Date	Description
Project:	CE Well Pad	1	9/26/22	Issued As Attachment To The Permit

E. Lighting Impacts up to 1 mile

The following locations were used to determine lighting impacts on RBU within 1 mile.

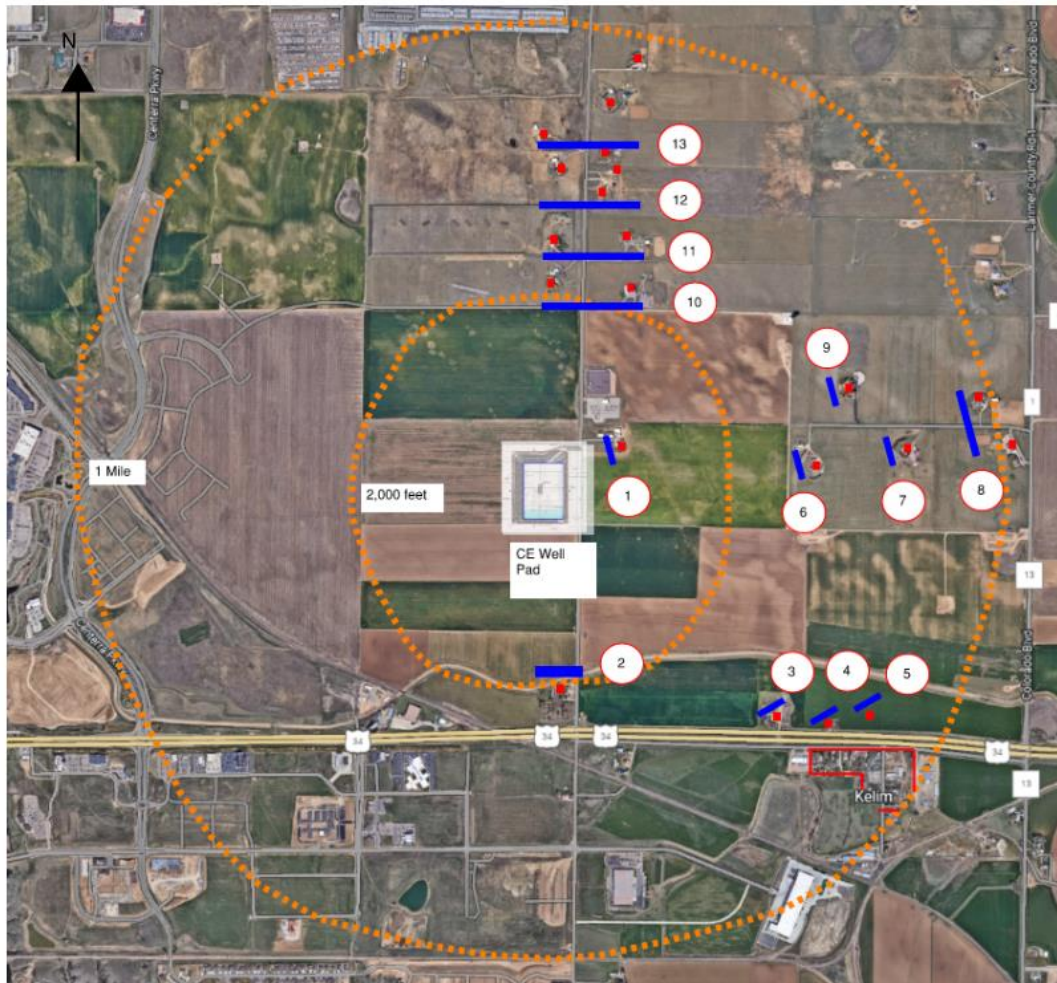

■	<u>KEY</u>	<u>CE Pad RBU and Model Simulations Locations</u>
■	RBU	NTS
—	1	Location of target wall for simulations of lighting impacts



				
REPORT				
Client:	MRG Oil and Gas	Rev	Date	Description
Project:	CE Well Pad	1	9/26/22	Issued As Attachment To The Permit

The following are the results of the simulations.

Preproduction Drilling



Target Wall Number	Resulting Impact
1	0.1 lux
2	< 0.1 lux
3	< 0.1 lux
4	< 0.1 lux
5	< 0.1 lux
6	< 0.1 lux
7	< 0.1 lux
8	< 0.1 lux
9	< 0.1 lux
10	< 0.1 lux
11	< 0.1 lux
12	< 0.1 lux
13	< 0.1 lux

Preproduction Completions



Target Wall Number	Resulting Impact
1	< 0.1 lux
2	< 0.1 lux
3	< 0.1 lux
4	< 0.1 lux
5	< 0.1 lux
6	< 0.1 lux
7	< 0.1 lux
8	< 0.1 lux
9	< 0.1 lux
10	0.1 lux
11	0.1 lux
12	0.1 lux
13	0.1 lux



				
REPORT				
Client:	MRG Oil and Gas	Rev	Date	Description
Project:	CE Well Pad	1	9/26/22	Issued As Attachment To The Permit

Production

Target Wall Number	Resulting Impact
1	< 0.1 lux
2	< 0.1 lux
3	< 0.1 lux
4	< 0.1 lux
5	< 0.1 lux
6	< 0.1 lux
7	< 0.1 lux
8	< 0.1 lux
9	< 0.1 lux
10	< 0.1 lux
11	< 0.1 lux
12	< 0.1 lux
13	< 0.1 lux



				
REPORT				
Client:	MRG Oil and Gas	Rev	Date	Description
Project:	CE Well Pad	1	9/26/22	Issued As Attachment To The Permit

F. Lumens per Square Feet Calculations

The following lighting layouts were used for the calculation of lumens per square foot.



Preproduction Drilling

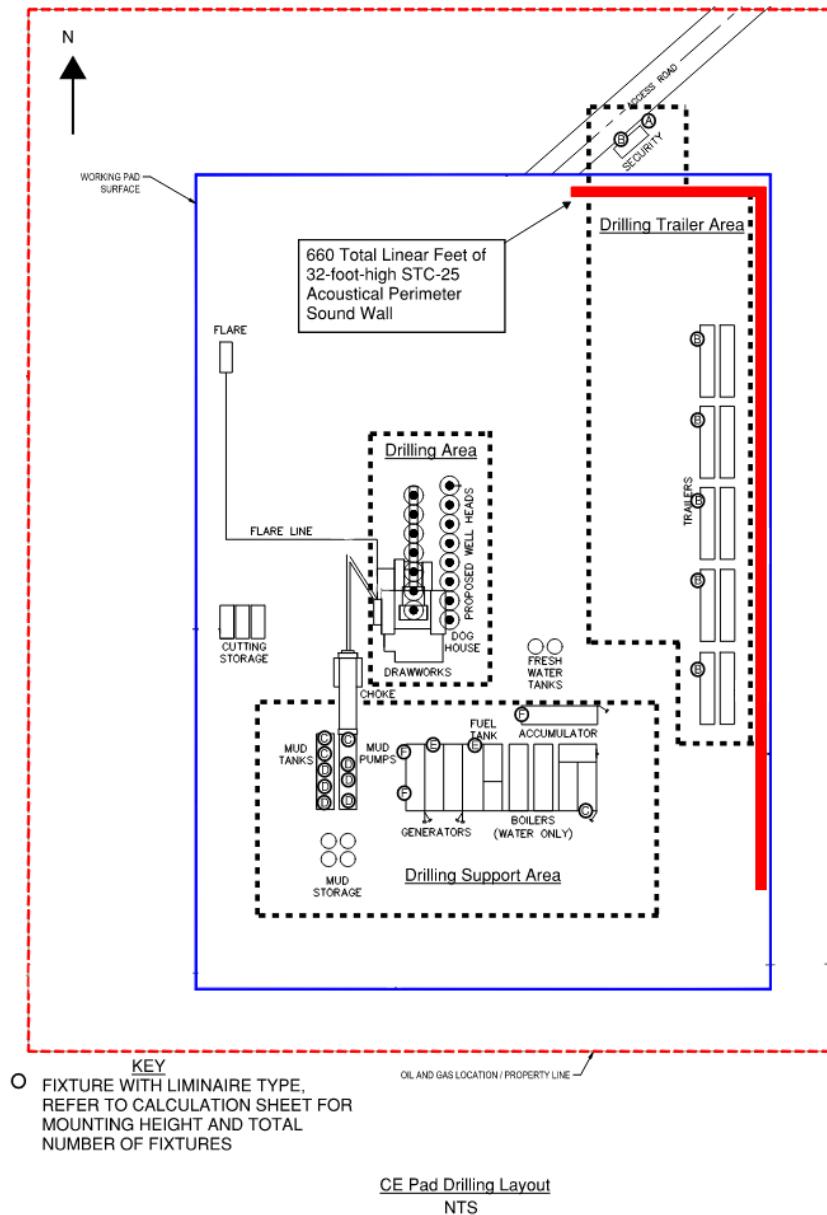

				
REPORT				
Client:	MRG Oil and Gas	Rev	Date	Description
Project:	CE Well Pad	1	9/26/22	Issued As Attachment To The Permit

Preproduction Drilling Rig

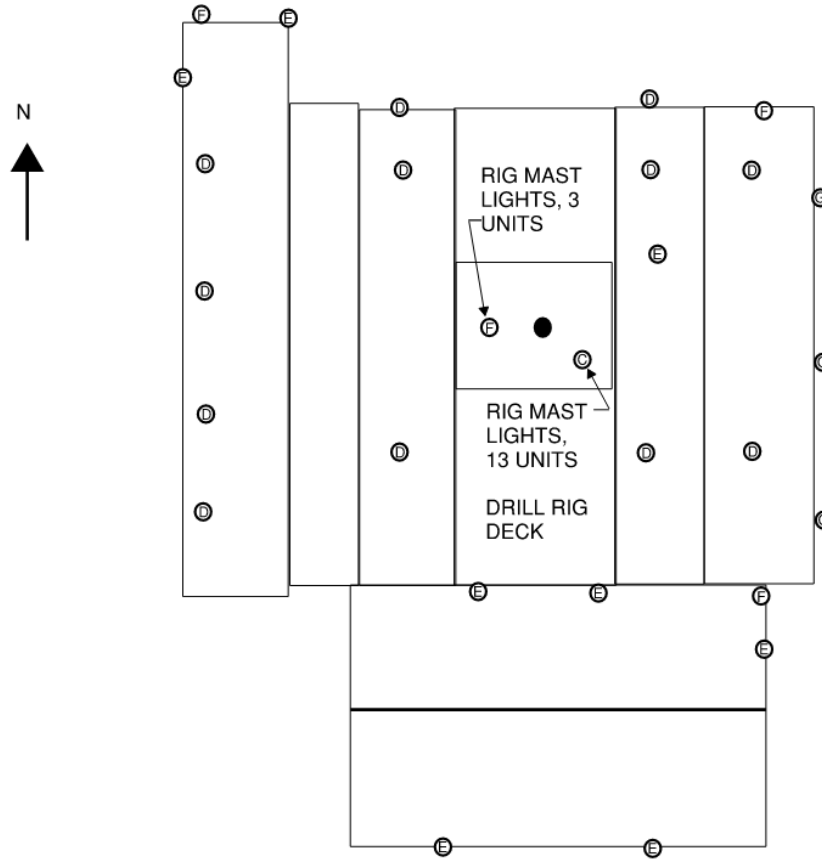

- KEY**
- FIXTURE WITH LIMINAIRE TYPE, REFER TO CALCULATION SHEET FOR MOUNTING HEIGHT AND TOTAL NUMBER OF FIXTURES

CE Pad Drilling Area Rig Layout
NTS



				
REPORT				
Client:	MRG Oil and Gas	Rev	Date	Description
Project:	CE Well Pad	1	9/26/22	Issued As Attachment To The Permit

1

Preproduction Completions

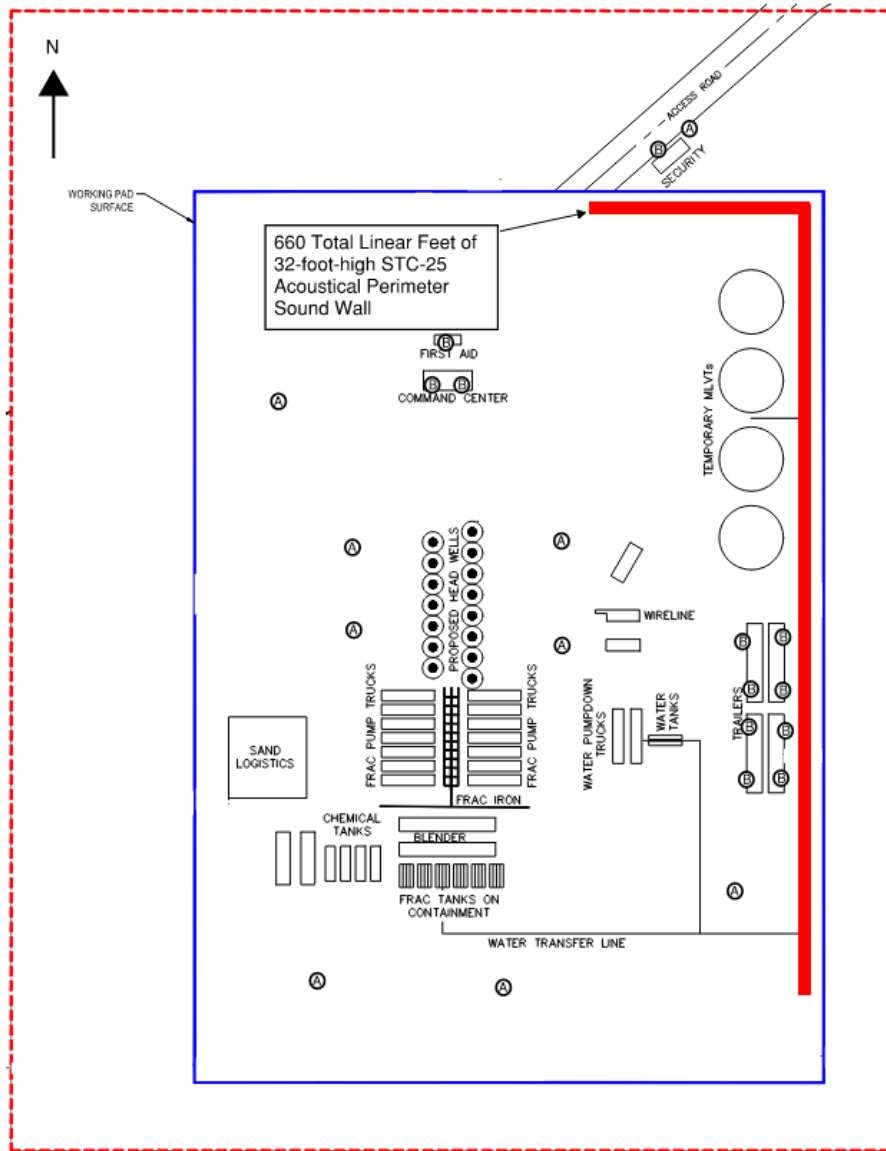

- KEY**
- FIXTURE WITH LIMINAIRE TYPE, REFER TO CALCULATION SHEET FOR MOUNTING HEIGHT AND TOTAL NUMBER OF FIXTURES

CE Pad Completions Layout
NTS



				
REPORT				
Client:	MRG Oil and Gas	Rev	Date	Description
Project:	CE Well Pad	1	9/26/22	Issued As Attachment To The Permit

1 Production Photometric Plan

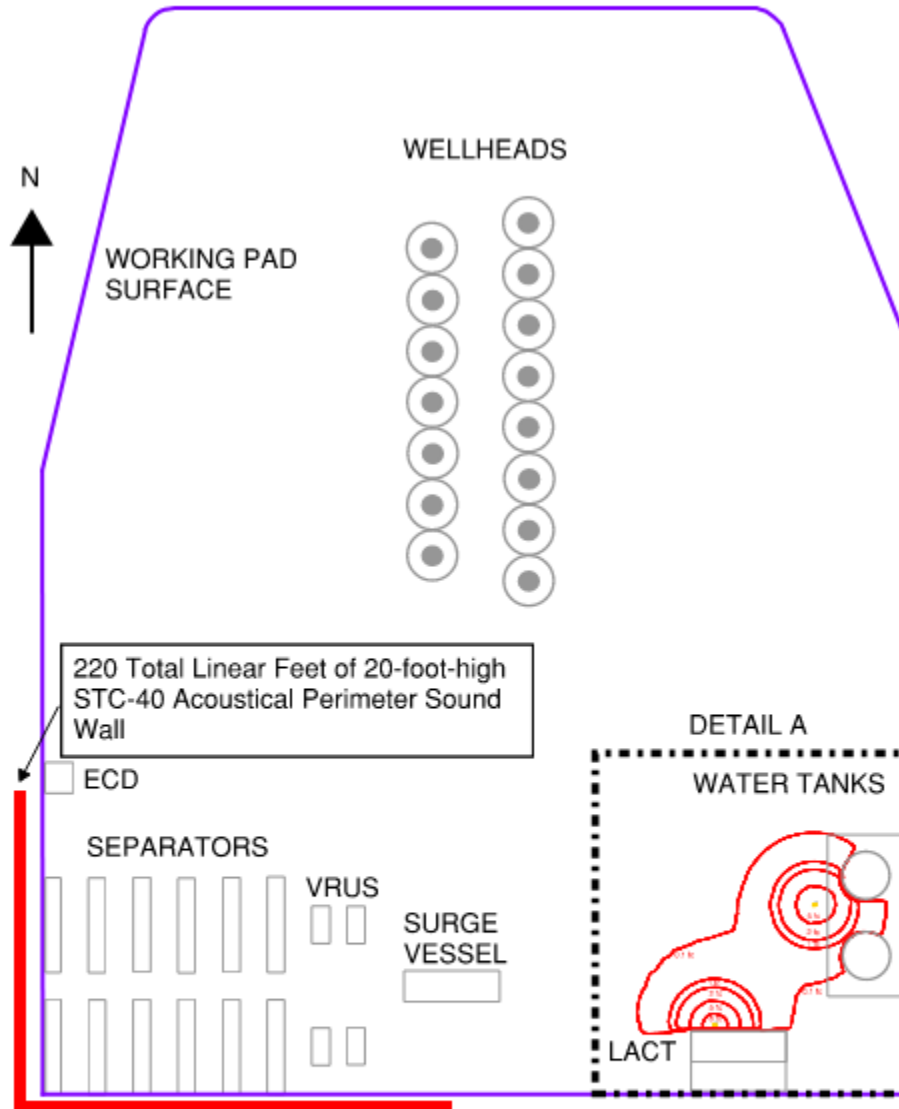

Production Pad Photometrics

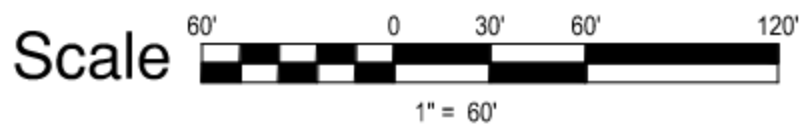

REPORT

Client:	MRG Oil and Gas	Rev	Date	Description
Project:	CE Well Pad	1	9/26/22	Issued As Attachment To The Permit

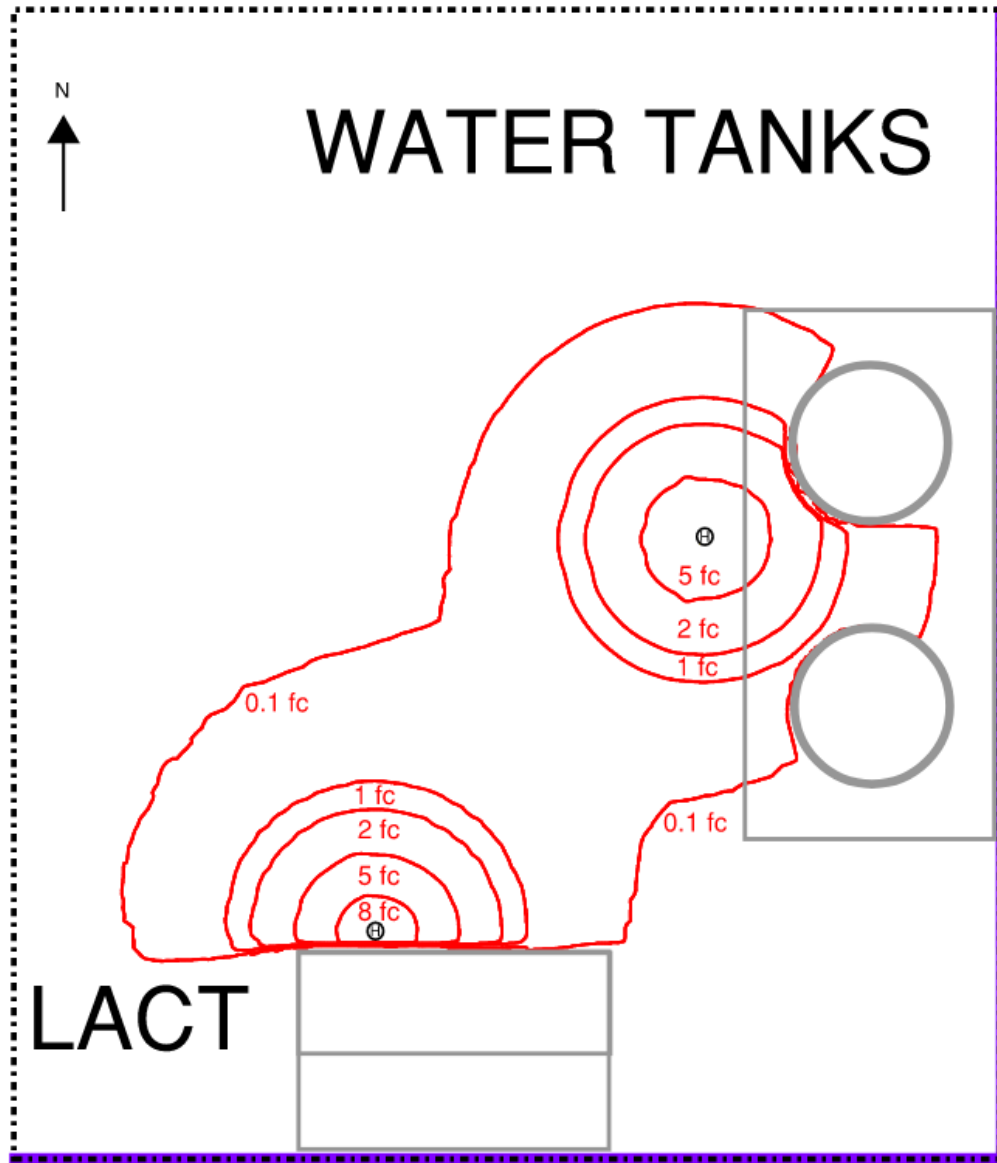

DETAIL A
Not To Scale

				
REPORT				
Client:	MRG Oil and Gas	Rev	Date	Description
Project:	CE Well Pad	1	9/26/22	Issued As Attachment To The Permit

The calculations for lumens per square foot are detailed in Attachments 1, 2, and 3.

G. Attachments

- Attachment 1 Preproduction Drilling Calculations Rev 0
- Attachment 2 Preproduction Completions Calculations Rev 0
- Attachment 3 Production Calculations Rev 0
- Attachment 4 Luminaire Information Rev 0



Attachment 1

Preproduction Drilling

Calculations

Preproduction Drilling Summation	
Lumens Per Square Foot	
Site Hardscape (Footage):	87,120 ft ²
Site Acres:	2.00 ACRES
Site Total Lumens:	1,038,871 lm
Base Allowance:	12 lm/(ft ²)
Site Allowance Initial Lumens Total:	1,045,440 lm
Calculated Site (Lumens / ft ²):	11.9 lm/(ft ²)

Drilling Lumen Subtotal Calculations	
Preproduction - Drill Rig Area Lights	714,181 lm
Preproduction - Drilling Support Area	201,890 lm
PreProduction - Drilling Trailer Area	122,800 lm
Total Area Lumens:	1,038,871 lm

Luminaire Schedule				
Luminaire Type	Model Number	Manufacturer	Lumens	Description
A	M4	HP WINNER	88,000 lm	LIGHT MAST
B	WPS	STANPRO	5,800 lm	WALL MOUNT EXTERIOR
C	DL44/UNV1 S903	EATON - COOPER CROUSE HINDS	7,619 lm	LED - 4FT LINEAR POLYCARBONATE LENS
D	HEU4MC2ANNWNGN	DIALIGHT	11,500 lm	LED - HIGH BAY
E	DFLYM400	EATON - COOPER CROUSE HINDS	40,000 lm	HID - HAZ. Area CLEAR GLASS
F	DL2/UNV1 S903	EATON - COOPER CROUSE HINDS	3,938 lm	LED - 2FT LINEAR POLYCARBONATE LENS

Preproduction - Drill Rig Area Lights

Luminaire Position and Tilt				
Luminaire Number:	Mounting Height (Feet)	Tilt	Luminaire Type	Lumens
1	45'	90°	C	7,619 lm
2	53'	90°	C	7,619 lm
3	60'	90°	C	7,619 lm
4	68'	90°	C	7,619 lm
5	76'	90°	C	7,619 lm
6	83'	90°	C	7,619 lm
7	91'	90°	C	7,619 lm
8	99'	90°	C	7,619 lm
9	106'	90°	C	7,619 lm
10	114'	90°	C	7,619 lm
11	122'	90°	C	7,619 lm
12	129'	90°	C	7,619 lm
13	137'	90°	C	7,619 lm
14	24'	0°	D	11,500 lm
15	24'	0°	D	11,500 lm
16	24'	0°	D	11,500 lm
17	24'	0°	D	11,500 lm
18	24'	0°	D	11,500 lm
19	24'	0°	D	11,500 lm
20	24'	0°	D	11,500 lm
21	24'	0°	D	11,500 lm
22	24'	0°	D	11,500 lm
23	20'	0°	D	11,500 lm
24	20'	0°	D	11,500 lm
25	20'	0°	D	11,500 lm
26	21'	75°	E	40,000 lm
27	21'	75°	E	40,000 lm
28	21'	75°	E	40,000 lm
29	21'	75°	E	40,000 lm
30	21'	75°	E	40,000 lm
31	21'	75°	E	40,000 lm
32	21'	75°	E	40,000 lm
33	44'	75°	E	40,000 lm
34	38'	75°	F	3,638 lm
35	38'	75°	F	3,638 lm
36	9'	75°	F	3,638 lm
37	45'	0°	F	3,638 lm
38	45'	0°	F	3,638 lm
39	45'	0°	F	3,638 lm
40	38'	75°	G	45,102 lm
41	38'	75°	G	45,102 lm
42	38'	75°	G	45,102 lm
Total Lumens CALCULATION				
Total Area Lumens:				714,181 lm

MRG Oil and Gas
 Project: CE Well Pad
 Date: 8/3/22
 Revision: 0
 Preproduction - Drilling Support Area

Luminaire Position and Tilt				
Luminaire Number:	Mounting Height (Feet)	Tilt	Luminaire Type	Lumens
42	9'	75°	C	7,619 lm
43	9'	75°	C	7,619 lm
44	9'	75°	C	7,619 lm
45	15'	0°	C	7,619 lm
46	15'	0°	D	11,500 lm
47	15'	0°	D	11,500 lm
48	15'	0°	D	11,500 lm
49	15'	0°	D	11,500 lm
50	15'	0°	D	11,500 lm
51	15'	0°	D	11,500 lm
52	15'	0°	D	11,500 lm
53	15'	75°	E	40,000 lm
54	15'	75°	E	40,000 lm
55	9'	75°	F	3,638 lm
56	9'	75°	F	3,638 lm
57	9'	75°	F	3,638 lm
Total Lumens Calculation				
Total Area Lumens:				201,890 lm

PreProduction - Drilling Trailer Area

Luminaire Position and Tilt				
Luminaire Number	Mounting Height (Feet)	Tilt	Luminaire Type	Lumens
57	16'	75°	A	88,000 lm
58	11'	0°	B	5,800 lm
59	11'	0°	B	5,800 lm
60	11'	0°	B	5,800 lm
61	11'	0°	B	5,800 lm
62	11'	0°	B	5,800 lm
63	11'	0°	B	5,800 lm
Total Lumens Calculation				
Total Area Lumens:				122,800 lm

Attachment 2 Preproduction Completions Calculations

MRG Oil and Gas
 Project: CE Well Pad
 Date: 8/3/22
 Revision: 0

Preproduction Completions Summation	
Lumens Per Square Foot	
Site Hardscape (Footage):	87,120 ft ²
Site Acres:	2.00 ACRES
Site Total Lumens:	861,600 lm
Base Allowance:	12 lm/(ft ²)
Site Allowance Initial Lumens Total:	1,045,440 lm
Calculated Site (Lumens / ft ²):	9.9 lm/(ft ²)

Completions Lumen Subtotal Calculations		
Pre-Production Completions		861,600 lm
Total Area Lumens:		861,600 lm

Luminaire Schedule				
Luminaire Type	Model Number	Manufacturer	Lumens	Description
A	M4	HP WINNER	88,000 lm	LIGHT MAST
B	WPS	STANPRO	5,800 lm	WALL MOUNT EXTERIOR

Pre-Production Completions

Luminaire Position and Tilt				
Luminaire Number:	Mounting Height (Feet)	Tilt	Luminaire Type	Lumens (Φ)
76	16'	75°	A	88,000 lm
77	16'	75°	A	88,000 lm
78	16'	75°	A	88,000 lm
79	16'	75°	A	88,000 lm
80	16'	75°	A	88,000 lm
80	16'	75°	A	88,000 lm
80	16'	75°	A	88,000 lm
80	16'	75°	A	88,000 lm
80	16'	75°	A	88,000 lm
80	16'	75°	A	88,000 lm
85	11'	0°	B	5,800 lm
86	11'	0°	B	5,800 lm
87	11'	0°	B	5,800 lm
88	11'	0°	B	5,800 lm
85	11'	0°	B	5,800 lm
86	11'	0°	B	5,800 lm
87	11'	0°	B	5,800 lm
88	11'	0°	B	5,800 lm
88	11'	0°	B	5,800 lm
88	11'	0°	B	5,800 lm
88	11'	0°	B	5,800 lm
88	11'	0°	B	5,800 lm
88	11'	0°	B	5,800 lm
88	11'	0°	B	5,800 lm
Total Lumens Calculation				
Total Area Lumens:				861,600 lm

Attachment 3 Production Calculations

MRG Oil and Gas
 Project: CE Well Pad
 Date: 8/3/22
 Revision: 0

Production Summation	
Lumens Per Square Foot	
Site Hardscape (Footage):	87,120 ft ²
Site Acres:	2.00 ACRES
Site Total Lumens:	5,800 lm
Base Allowance:	5 lm/(ft ²)
Site Allowance Initial Lumens Total:	435,600 lm
Calculated Site (Lumens / ft ²):	0.1 lm/(ft ²)

Production Lumen Subtotal Calculations		
Production Site Total		
	Total Area Lumens:	5,800 lm

Luminaire Schedule				
Luminaire Type	Model Number	Manufacturer	Lumens	Description
H	VMV3LWD5 W/ VISOR	APPLETON	2,900 lm	WALL MOUNT EXTERIOR
H	VMV3LWD5 W/ VISOR	APPLETON	2,900 lm	PENDANT

Production

Luminaire Position and Tilt				
Luminaire Number:	Mounting Height (Feet)	Tilt	Luminaire Type	Lumens (Φ)
89	12'	0°	H	2900 lm
90	12'	0°	H	2900 lm
Total Lumens Calculation				
Total Area Lumens:				5800 lm

Attachment 4

Luminaire Information

TYPE A

Notes:

1. Type A fixture are portable light masts. These unit vary based on supplier and rental agency, and inventory. A representative model is used based on typical vendor information.
2. The light poles are pointed at work area and downward.
3. The unit is comprised of 16 modules total and estimated at a total output of 88,000 lumens per mast.

TYPE A Model Example Used



LED Module M8B Series

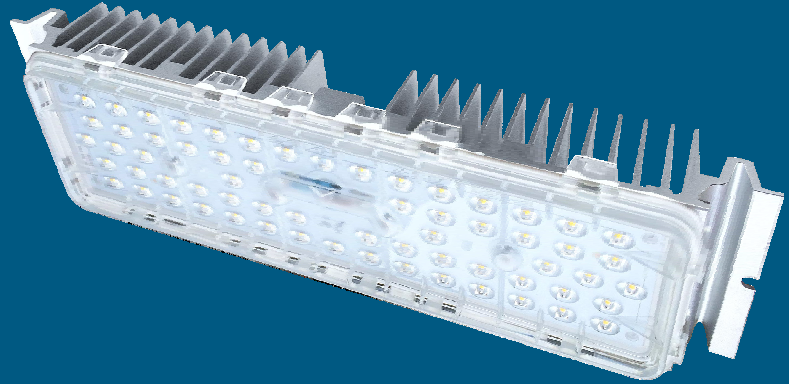

Specification

Working Environment: -40°C~+50°C

Storage Temperature: -40°C~+50°C

Relative humidity: 10%~90%RH

Typical value of pad temperature^[1]: 70°C

IP Rating of LED Light Engine: IP68

Impact Protection Level: IK09

Color Temperature (CCT)^[2]: 3000K, 4000K, 5000K, 5700K

Main Material: Aluminum 6063

Module N.W.: 0.67±0.04 kg

Note :

[1] Typical values of pad temperature is obtained based on 60W with a ambient temperature of 25°C.

[2] Efficacy of 3000K is 5% lower than other CCTs.

Features

- Lumileds Luxeon 3030;
- Super long lifetime(Lumen maintenance);
- Multiple lighting distributions available;
- Wide applicability for complex situations;
- High versatility apply for all sorts of lamps retrofit.

Application

- Street lighting retrofit and application;
- Factory lighting retrofit and application;
- Tunnel lighting retrofit and application;
- Sports lighting retrofit and application.

Ordering Information

For example: M8B-VCA-63 -1321-7040-LU

Module Model	Interface	Dimension of LEDS	Wire Material	LED Qty	Lens Model		Ra & CCT	LED Brand
M8B	V: V-shape Groove	C: 3030	A: CCC+VDE	49 49PCS	1324 Type II Short	1325 25 DEG	7030: Ra≥70, 3000K 8040: Ra≥80, 4000K ...	LU: Lumileds
			C: PSE	63 63PCS	2322 Type II Short (V)	2360 60 DEG		SN: Sanan
			H: UL		5321 Type II Short	5340 40 DEG		XX: Others
			X: Others		2321 Type II Short	5390 90 DEG		
					1321 Type III Medium	1310 Lambert Type		
				1390 Tunnel Lighting				

Performance

Model	Power (W)	Driving current (mA)	Input voltage (Vdc)	Efficacy (lm/W)	Lumens (lm)
M8B-VCA-63	40	700	48~61	140	5600
M8B-VCA-49	50	1050	38~48	127	6350
M8B-VCA-63	50	860	48~61	135	6750
M8B-VCA-63	60	1050	48~61	127	7620

Note : Values shown are subject to ±5%~±8% tolerance; Cable default A type;

Efficacy above is based on calculated @92% power efficiency ; Light efficacy of 3000K is 5% lower than other CCTs.

Dimensions

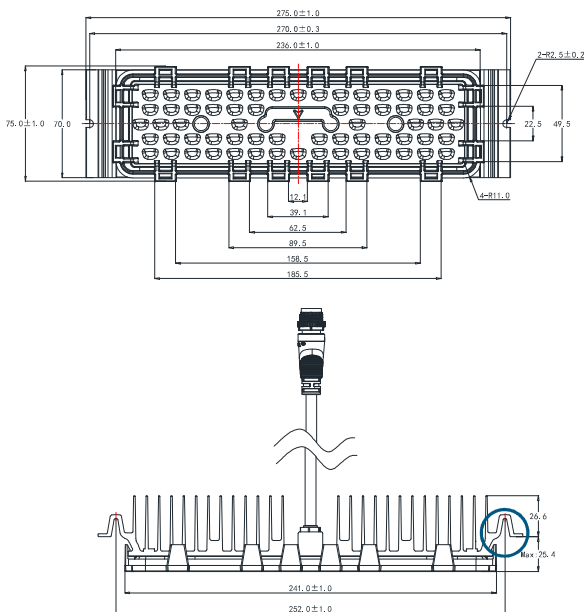

L (mm)	W (mm)	H (mm)
275	75	Max52

The height of the module is the maximum value.

Tolerance: ±0.5mm

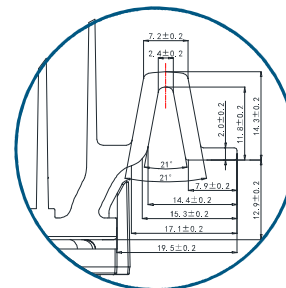

Available Lens Model

1321	1324	1390
1232	2322	5321

Dimensions

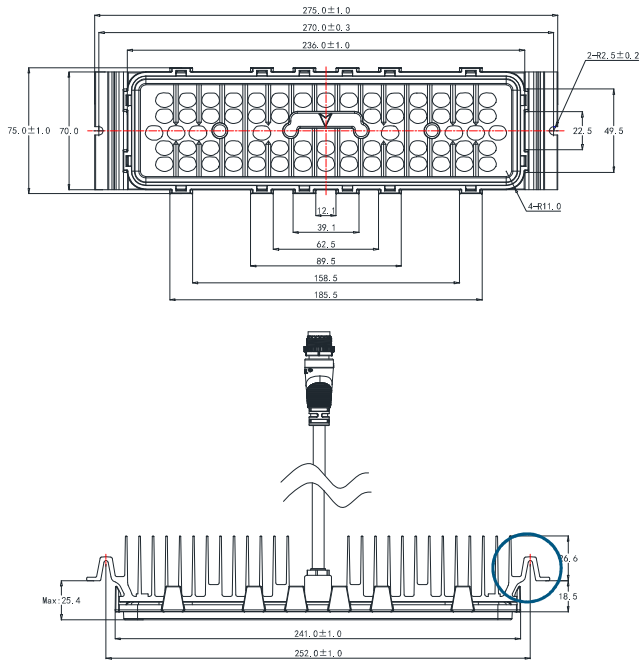

L (mm)	W (mm)	H (mm)
--------	--------	--------

275 75 Max52

The height of the module is the maximum value.

Tolerance: ±0.5mm

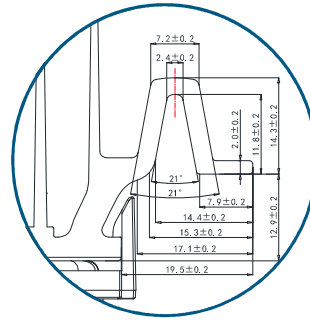

Available Lens Model

1310	1325	5340	2360
5390			

Package Information

L (mm)	W (mm)	H (mm)	Module pcs/carton (PCS)	Package weight (kg)
650	375	190	20	14.9

Values shown are subject to ±5% tolerance.

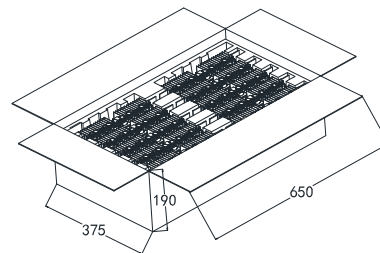
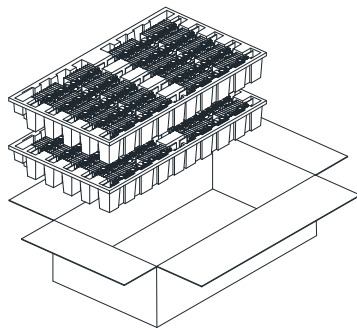

Lighting distributions

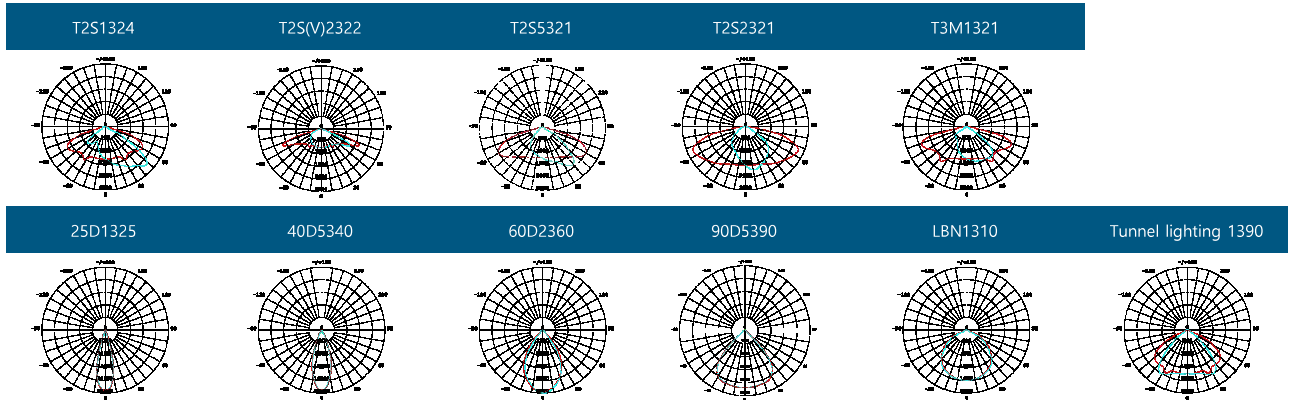

Version History

Change Date	Version	Description of Change		
		Item	From	To
20190905	Ver2.0	Data sheets release (new version) Update of luminous efficacy Optimized G.W of Module package	16.2kgs	14.9kgs

LUMINAIRE CLASSIFICATION SYSTEM (LCS) GRAPH

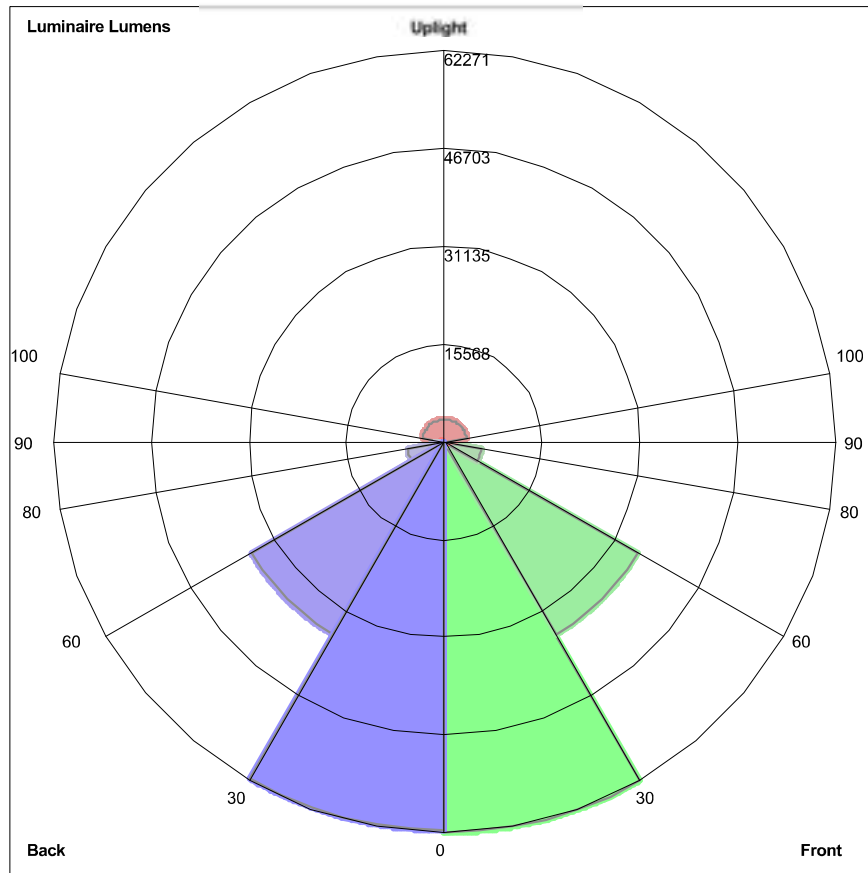

Luminaire Lumens:
Front: Low=62270.6, Medium=35421.7, High=5946.3, Very High= 1328.0
Back: Low= 61920.0, Medium=35466.8, High=5958.8, Very High=1320.7
Uplight: Low=493.0, High=3564.5

BUG Rating : B5-U5-G5

FIXTURE CUT SHEET

TYPE B

Series Spec Sheet

WPS GEN 4

CLASSIC WALL PACK

Selectable color temperature (3 000 K / 4 000 K / 5 000 K)¹

Power selectable¹

Integrated photocell¹

Multi-Voltage (120-347 V)¹

This wall pack series is a classic and familiar design integrated with modern LED technology to promote better energy efficiency and long life. Certain configurations come with integrated photocell, selectable power and/or selectable color temperature. It is best suited for entrances, underpasses or anywhere controlled security lighting is required, the series luminaire is a great addition to any commercial or industrial outdoor wall mount application. The tough die cast aluminum housing is moisture and dustproof. ¹

FEATURES AND SPECIFICATIONS

• Construction

Housing

- This luminaire is made of aluminum die cast and comes standard in a bronze powder coat finish.
- The housing has four conduit entries of 1/2" on each sides and some of the configurations comes with a button type photocell that can be turned off by using the internal switch if needed.¹

Lens

Prismatic tempered glass lens is standard in this product series.

• Electrical

- The drivers allows an input voltage from 120-277 V or 120-347 V AC 50/60 Hz and are 0-10 V dimmable. They are coming with an onboard surge protection:
 - NS29: 2.5kV standard
 - NS40, NS60, NS80, PS40, PS100: 2kV standard
 - NS120: 4kV standard

- This wall pack series is suitable for ambient temperature range of -40°C to +50°C. Available in color temperatures of 4 000 K, 5 000 K or 3CCT selectable (3 000/4 000/5 000 K) with a lumen per watt ratio of 140 lm/W to 152 lm/W depending on the lumen package.
- The color temperature of the fixture is set by default at 4 000 K and can be changed on the field.

• Compliances

- Wet location
- IP65
- Meets requirements of ICES-005 issue 5 for class B products
- cULus
- IK06
- BC Hydro

OVERVIEW

Light source	LED
Watts (W)	25/30/40, 60/80/100 30, 40, 60, 80, 120
Lumens output (lm)	3 625 - 17 885
Efficiency (lm/W)	140 - 152
Color temperature (K)	3CCT (3 000/4 000/5 000) 4 000, 5 000
CRI	> 80

¹ Integrated photocell, multi-volt driver, CCT and Power selectable on some configurations. Consult Quick ship and technical specification table for more details.



quick ship



LED fixture



power selectable¹



3 CCT ICC
3000 K / 4000 K / 5000 K



dimmable fixture



wet location



ICES 005



IK06



Not all products are qualified on the DLC QPL. To view our DLC qualified products, please consult the DLC Qualified Products List at www.designlights.org/search.

QUICK SHIP AND TECHNICAL SPECIFICATION TABLE  ¹

Order code	Model number	DLC unique ID	Watts (W)	Volts (V)	Color temp. (K) ²	Lumen output (lm) ³	Efficiency (lm/W)	Photo-cell ⁴	CRI	Life L70 (hrs) ⁵	Tested hours LM-80 (hrs) ⁵	Calculated TM21 (hrs) ⁵	Finish	Dimming	B.U.G.	LED current (mA)	Power factor	THD (%)	Case qty (master)
Power Select, CCT Select and Integrated Photocell⁶																			
68314	WPS-PS40-Q-3C	PLW61NEJG50K	25/30/40	120-347	3000/4000/5000	3875/4500/5800 ³	141	Yes	>80	54 000	9 000	173 600	Bronze	Yes	B1U3G4	850	≥0.9	≤20	1
68315	WPS-PS100-Q-3C	PLE7PYF9LCSH	60/80/100	120-347	3000/4000/5000	9300/12000/14500 ³	137	Yes	>80	54 000	9 000	173 600	Bronze	Yes	B1U3G4	2 100	≥0.9	≤20	1
Single Power, Single CCT and Integrated Photocell⁶																			
68524	WPS-NS30-W-40K/P127		29	120-277	4 000	4 200	150	Yes	>80	54 000	9 000	173 600	Bronze	Yes	B1U3G5	230	≥0.9	≤20	1
68525	WPS-NS30-W-50K/P127		29	120-277	5 000	4 300	148	Yes	>80	54 000	9 000	173 600	Bronze	Yes	B1U3G5	230	≥0.9	≤20	1
Single Power and Single CCT																			
68490	WPS-NS40-W-40K	PLVM09BUX07G	40	120-277	4 000	6 004	142	No	>80	54 000	9 000	173 600	Bronze	Yes	B1U3G4	354	≥0.9	≤20	1
68491	WPS-NS40-W-50K	PL3ULW7TEV5H	40	120-277	5 000	6 034	144	No	>80	54 000	9 000	173 600	Bronze	Yes	B1U3G4	354	≥0.9	≤20	1
68492	WPS-NS60-W-40K	PL6EFOU7BPWB	60	120-277	4 000	8 458	146	No	>80	54 000	9 000	173 600	Bronze	Yes	B1U3G5	486	≥0.9	≤20	1
68493	WPS-NS60-W-50K	PL01JETYSQ80	60	120-277	5 000	8 611	147	No	>80	54 000	9 000	173 600	Bronze	Yes	B1U3G5	486	≥0.9	≤20	1
68497	WPS-NS80-W-40K	PLVXL8TOP2UF	80	120-277	4 000	11 242	146	No	>80	54 000	9 000	173 600	Bronze	Yes	B1U4G5	645	≥0.9	≤20	1
68498	WPS-NS80-W-50K	PL2AZJG3LORQ	80	120-277	5 000	11 446	148	No	>80	54 000	9 000	173 600	Bronze	Yes	B1U4G5	645	≥0.9	≤20	1
Single Power, CCT Select and Integrated Photocell⁶																			
68316	WPS-NS120-Q-3C	PLYRMZYS3AY3	120	120-347	3000/4000/5000	16 943	137	Yes	>80	54 000	9 000	173 600	Bronze	Yes	B2U4G5	2 600	≥0.9	≤20	1

¹ **QUICK SHIP:** Product availability is subject to change without notice. Please contact your Stanpro customer service representative to confirm inventory levels at time of order.

² Typical color temperature range: +/- 5 %.

³ Lumen values are derived from photometric testing. Initial lumens range: +/- 10 %.

⁴ Lumen values are based on 4 000 K default settings. Please refer to Quick ship Technical Specification Table for more details on other color temperatures.

⁵ Life hours are derived from IESNA LM-80-08 testing report and projected per IESNA TM-21-11 extrapolations.

⁶ Integrated ON/OFF photocell that can be easily disabled.

ACCESSORIES (order separately)

Order code	Description
68370	18" Bronze metal backplate
68371	Bronze glareshield
68372	Stainless Steel wireguard



ORDERING GUIDE

Series	Lumen package (W)	Volts (V)	Color temp. (K)	Casting color	Options
WPS	PS40 - 25/30/40 PS100 - 60/80/100 NS120 - 120	Q - 120-347	3C - 3 000/4 000/5 000	BR - Bronze (standard) BK - Black WH - White	KV - 10 kV surge Protection PC - Polycarbonate lens
	NS30 ¹ - 29 NS40 - 40 NS60 - 60 NS80 - 80	W - 120-277	40K - 4 000 50K - 5 000	SP- Special color	KV - 10 kV surge Protection P127 ¹ - Button type photocell 120-277 V PC - Polycarbonate lens

¹ Button type photocell 120-277 V comes standard with the "NS30" lumen package.

Data is based upon tests performed in a controlled environment. Actual performance can vary depending on operating conditions. All products are subject to change or may be discontinued any time without notice.

DIMENSIONS

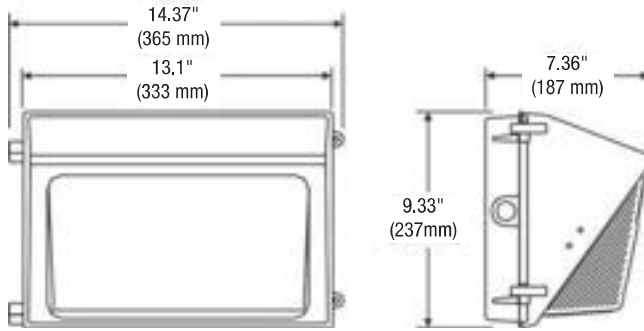

BACKPLATE

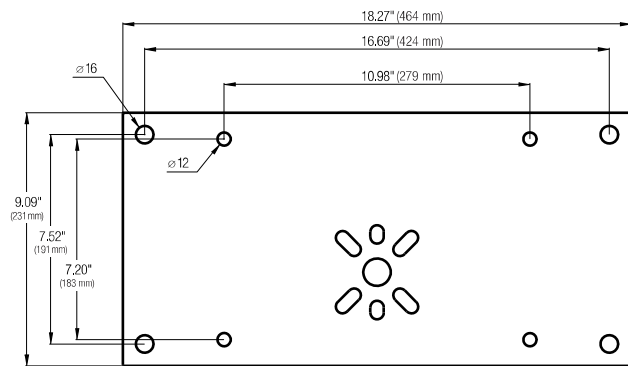

GLARESHIELD

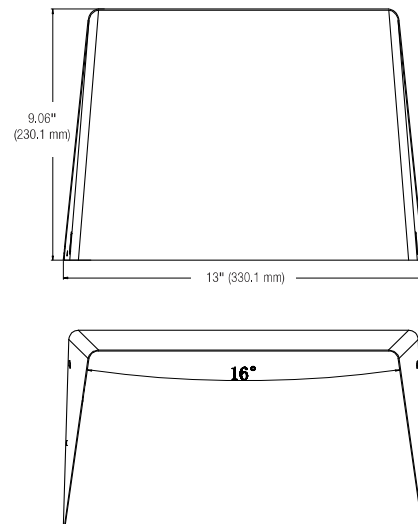

WIREGUARD

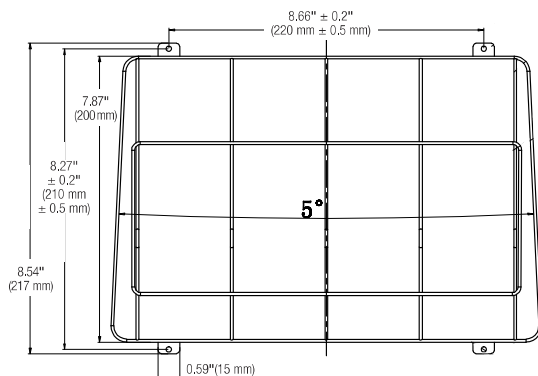

Data is based upon tests performed in a controlled environment. Actual performance can vary depending on operating conditions. All products are subject to change or may be discontinued any time without notice.

LUMINAIRE CLASSIFICATION SYSTEM (LCS) GRAPH

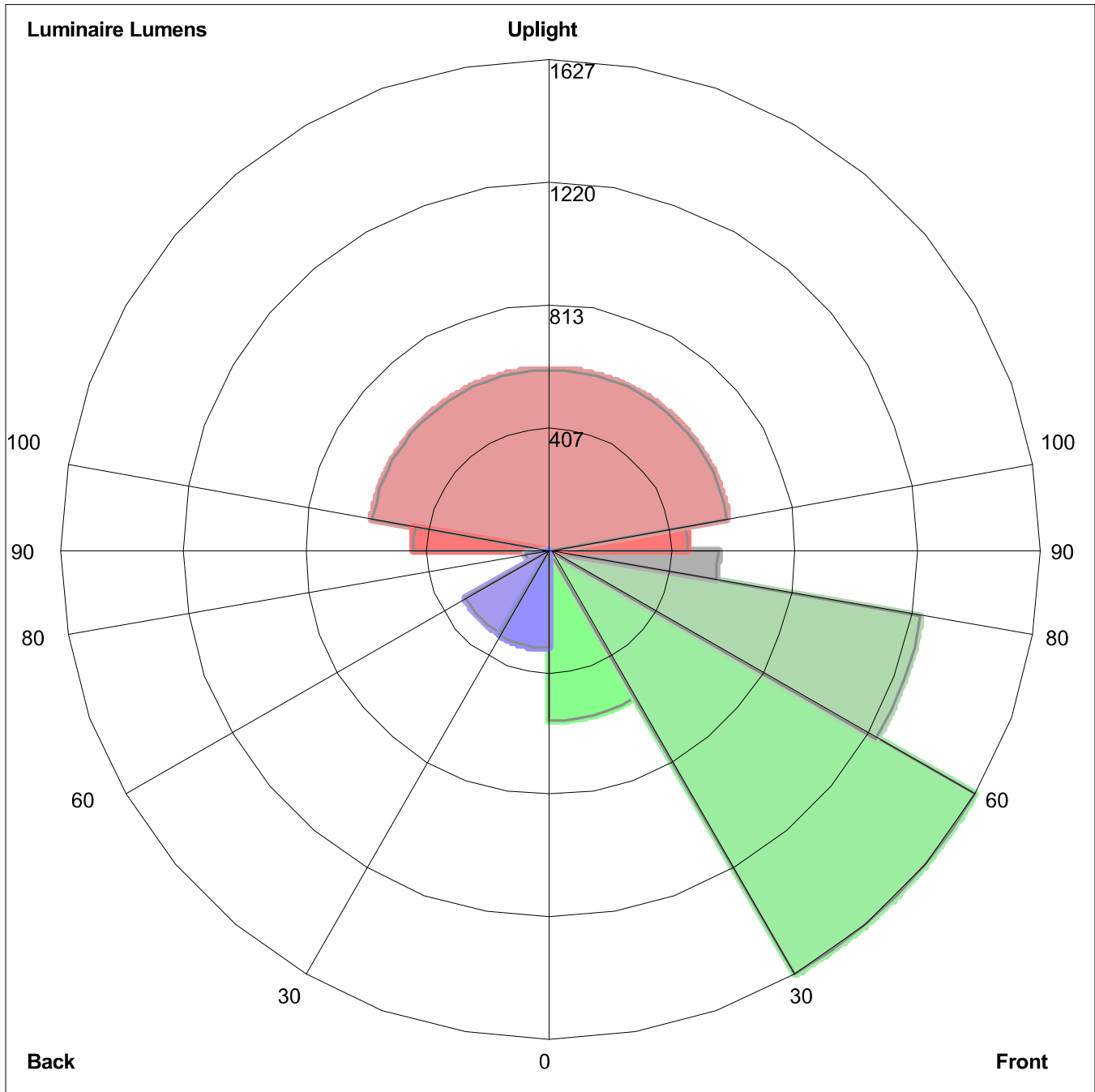

Luminaire Lumens:
Front: Low=566.0, Medium=1626.5, High=1251.8, Very High=558.0
Back: Low=327.7, Medium=323.2, High=79.4, Very High=11.6
Uplight: Low=456.3, High=599.7

BUG Rating : B1-U4-G4

FIXTURE CUT SHEET

TYPE C

Pauluhn DLL LED Luminaires

For land-based drilling

Cl. I, Div. 2, Groups A, B, C, D
Cl. I, Zone 2
Cl. II, Div. 2, Groups F, G
Cl. III

UL Listed
CSA Certified
Marine & Wet Locations
NEMA 4X; IP66

2L

2L

The Pauluhn™ DLL linear LED is specifically designed to replace fluorescent T12, T8 and T5HO lighting on land-based and offshore drilling platforms. The rugged and durable design features the industry's most versatile and flexible mounting options. The Pauluhn DLL is the ideal solution for high vibration, impact and hose down in drilling applications.

Model	Typical lumens	Watts	Lumens per watt	Equivalent HID luminaire	Typical energy savings / lifetime
DLL2	3,958	32	124	T12HO	Up to 63%
				T8HO	Up to 59%
				T5HO	Up to 47%
				T12	Up to 36%
				T8	Up to 25%
DLL4	7,900	63	130	T5	Up to 9%
				T12HO	Up to 58%
				T8HO	Up to 54%
				T5HO	Up to 43%
				T12	Up to 37%
				T8	Up to 22%
				T5	Up to 10%

Applications:

- Land-based and offshore rigs; areas include: derrick, mast, SCR house, top drive, operator's house, power and pump stations

Features:

- High efficacy: up to 120 LPW
- 40°C to +65°C ambient operating temperature (standard model)
- Low profile (<3" height)
- Versatile ceiling/swivel, wall, flush, pole and pendant mounting options
- Wide and narrow optics for uniform illumination in control room and drill mast
- Four points of secondary retention
- 2,000 PSI high pressure hose rated
- High vibration resistance
- Emergency battery back-up (90 minutes) and surge protection options (up to 10 kV) [Ⓐ]
- DesignLights Consortium® Qualified (some models are not DLC qualified) [Ⓑ]
- 5 year fixture warranty

Standard materials:

- Housing – copper-free aluminum; Corro-free epoxy powder coat (optional)
- Lens – clear polycarbonate; diffused polycarbonate

Photometrics:

- Complete photometrics can be found at www.crouse-hinds.com/photometrics

Temperature performance data:

Ambient temp. °C	Min. temp. supply wire °C	Simultaneous rating		
		Class I, Div. 2	Class II, Div. 2	Class I, Div. 2; Class II, Div. 2
40	60	T6	T6	T6
55	75	T5	T5	T5
65	90	T5	T5	T5



Mounting (ordered separately):

Versatile mounting options:

- Flush back mount
- Swivel/ceiling back mount
- Offset ceiling mount
- Offset wall mount
- Pole mount
- Pendant mount

Easily retrofit to:

- Existing Pauluhn DuraPro and MagnaPro fluorescent light fixtures
- Rig-A-Lite and Snelson C1D2 fluorescent lighting fixtures

Certifications and compliances:

NEC:

- Class I, Division 2, Groups A, B, C, D
- Class I, Zone 2
- Class II, Division 2, Groups F, G
- Class III
- NEMA 4X, IP66
- Marine and wet locations

UL standards:

- UL844 – Electrical Fixture Hangers for Hazardous Locations
- UL1598 – Luminaire
- UL1598A – Luminaire for Installation on Marine Vessels
- UL924 – Emergency Lighting

CSA standard:

- C22.2 No. 137

Additional certifications:

- ABS design assessed

Electrical ratings:

	DLL2	DLL4
Lumen output	3,958	7,900
Frequency	50/60 Hz	50/60 Hz
Voltage	100-277 VAC, 108-250 VDC; 347-480 VAC	

Model	Voltage	Current (A)	Watts	Power factor	THD
DLL2/UNV1	100	0.33	32.5	0.92	<20%
DLL2/UNV1	277	0.13	34.3	0.92	<20%
DLL2/UNV34	347	0.10	32.2	0.92	<20%
DLL2/UNV34	480	0.07	34.5	0.92	<20%
DLL4/UNV1	100	0.63	63.4	0.92	<20%
DLL4/UNV1	277	0.23	62.5	0.92	<20%
DLL4/UNV34	347	0.18	61.4	0.92	<20%
DLL4/UNV34	480	0.13	63.9	0.92	<20%

Weights:

Model	Lbs.	Kg.
DLL2	12.50	5.70
DLL4	22.50	10.20

[Ⓐ] One year warranty.

[Ⓑ] Refer to www.designlights.org Qualified Products List under Family Models for full listing details. Not all models are approved for all application categories.

Pauluhn DLL LED luminaires

For land-based drilling

Cl. I, Div. 2, Groups A, B, C, D
Cl. I, Zone 2
Cl. II, Div. 2, Groups F, G
Cl. III

UL Listed
CSA Certified
Marine & Wet Locations
NEMA 4X; IP66

2L

2L

Designed for drilling. Pauluhn DLL linear LED luminaires are engineered to handle demanding conditions faced on land-based drilling rigs. The DLL stands up to high vibration, hose down, shock and impact, while delivering long life and high lumen performance for up to 20 years.

Custom optics:

- Standard wide (120°) beam spread for control room and indoor application maximizes illumination on wall panels
- Narrow (80°) beam spread option for high mast/derrick application avoids spillage and light loss

Comprehensive certification:

- Single model certified for use in Class I, Division 2 and Class II, Division 2 harsh and hazardous applications

Quick & easy installation:

- Easy access to drivers and wiring
- No custom brackets or hardware needed
- Seven mounting options available
- Easily retrofit to Pauluhn DuraPro and MagnaPro, Rig-A-Lite and Snelson



Slim profile:

- 2.7" fixture height (excluding mounting brackets)
- Perfect for mounting in confined or low height areas

Built to last:

- Ingress protection from hose down water or diesel fuel in harsh operational conditions – passed 2,000 PSI high pressure test
- Vibration-, impact- and shock-resistant – passed 5G, 3-axis vibration test
- 60,000 hour lifetime at 55°C ambient



Pauluhn DLL LED luminaires

For land-based drilling

Cl. I, Div. 2, Groups A, B, C, D
Cl. I, Zone 2
Cl. II, Div. 2, Groups F, G
Cl. III

UL Listed
CSA Certified
Marine & Wet Locations
NEMA 4X; IP66

2L

2L

Ordering information:

Part number example

DLL4N/UNV1 S903 TF P EM1

DLL	4	N	/UNV1	S903	TF	P	EM1
Series	Optics	Lens	Options	Finish	Emergency back-up		
DLL Pauluhn DLL linear LED luminaire	BLANK Wide (120°) N Narrow (80°)	S903 Clear polycarbonate S903D Diffused polycarbonate	TF Pull wire included in fixture	BLANK Natural aluminum P Painted (gray, epoxy) WH Painted (white, epoxy)	BLANK Standard model (no battery back-up) EM1Ⓞ Integrated emergency battery back-up EM Remote emergency kit		
Length / lumens	Voltage						
4 4 ft. length, 7,900 lumens 2 2 ft. length, 3,958 lumens	/UNV1 100-277 VAC, 108-250 VDC /UNV34 347-480 VAC						

Accessories (ordered separately):

Description	Cat. #	Description	Cat. #
• Flush/back mount back plate.....	DP1057MTK <i>Compatible with DuraPro</i>	• Pendant mount kit.....	PEND HAZ KIT
• Ceiling/swivel mount.....	DP1050MTK <i>Compatible with DuraPro</i>	• Safety chain kit.....	SS KIT
• Ceiling/wall mount offset.....	DP1053MTK <i>Compatible with DuraPro</i>	• 1 amp driver replacement kit, 100-277 VAC for 4 ft. linear.....	VMVL/UNV1 80W 1A KIT
• Ceiling mount bracket and adapter kit.....	MP1054MTK KIT <i>Compatible with MagnaPro</i>	• 1 amp driver replacement kit, 347-480 VAC for 4 ft. linear.....	VMVL/UNV34 80W 1A KIT
• Offset wall mount.....	DP1052MTK <i>Compatible with DuraPro</i>	• 0.5 amp driver replacement kit, 100-277 VAC for 2 ft. linear.....	VMVL/UNV1 80W 0.5A KIT
• Pole mount kit, 1.25" conduit.....	PM KIT 1.25	• 0.5 amp driver replacement kit, 347-480 VAC for 2 ft. linear.....	VMVL/UNV34 80W 0.5A KIT
• Pole mount kit, 1.50" conduit.....	PM KIT 1.5		
• Pole mount kit, 2.00" conduit.....	PM KIT 2.0		

Dimensions and mounting options:

Technical drawings showing dimensions for DLL4 and DLL2 luminaires. Dimensions are provided in inches and millimeters.

DLL4 Dimensions: Length 1329.1 mm (52.33"), Mounting hole diameter 157.9 mm (6.22").

DLL2 Dimensions: Length 719.6 mm (28.33"), Mounting hole diameter 68.58 mm (2.70").

Mounting Options:

- Offset wall: DP1052MTK
- Flush ceiling: DP1057MTK
- Offset ceiling: DP1053MTK
- Ceiling/swivel: DP1050MTK
- Ceiling and adapter: MP1054MTK KIT
- Pole mount: PM KIT 1.25/1.5/2.0
- Pendant mount: PEND HAZ KIT

Ⓞ One year warranty. Remote EM kit also available, 120-277 VAC only. Available with 4 ft. model only.

Pauluhn DLL LED luminaires

Integral battery back-up

Cl. I, Div. 2, Groups A, B, C, D
Cl. II, Div. 2, Groups F, G

UL Listed
CSA Certified
Wet Locations
Type 4X; IP66

2L

2L

Pauluhn DLL linear LED luminaires are available with an integral battery back-up module. Virtually the same size as the standard 4 foot model and 90 minutes of emergency lighting to keep your facility and personnel safe.



Model	EM output	Normal output
DLL4/UNV1 S903 EM1	1,400 lumens (100-277V)	6,720 lumens (100-277V)

Applications:

- Egress and emergency lighting for areas requiring uninterrupted lighting during power failure
- Hazardous rated indoor and outdoor emergency lighting in manufacturing plants, heavy industrial, chemical and petrochemical facilities, platforms, loading docks and parking areas

Features:

- Operating ambient: 0°C to +40°C
- 90-minute run time in emergency mode
- 6,720 lumen output for normal operation; 1,400 lumen output in emergency mode
- 50,000 hours rated life at 40°C
- IP66 rated enclosure
- LED indicator to check battery operation
- Nickel cadmium battery
- 1 year warranty

Certifications and compliances:

NEC/CEC:

- Class I, Division 2, Groups A, B, C, D
- Class II, Division 2, Groups F, G
- Wet locations, Type 4X, IP66

UL standards:

- UL844 – Hazardous (Classified)
- UL1598 – Luminaires
- UL1598A – Marine
- UL924 – Emergency Lighting

CSA standard:

- CSA C22.2 Nos. 137, 141

Electrical ratings:

	EM output	Normal output
Voltage	120	277
Amperage at 120 VAC	0.480	0.212
Wattage at 120 VAC	57.8	57.7
Lumen output	1,400	6,720
Frequency	50/60 Hz	50/60 Hz
Power factor at 100 VAC	>0.90	>0.90
THD	6.58	11.70

Temperature performance data:

Ambient temp. °C	Min. temp. supply wire °C	Simultaneous rating		
		Class I, Div. 2	Class II, Div. 2	Class I, Div. 2; Class II, Div. 2
40	60	T5	T6	T5

Photometrics:

- Complete photometrics can be found at www.crouse-hinds.com/photometrics

Dimensions:

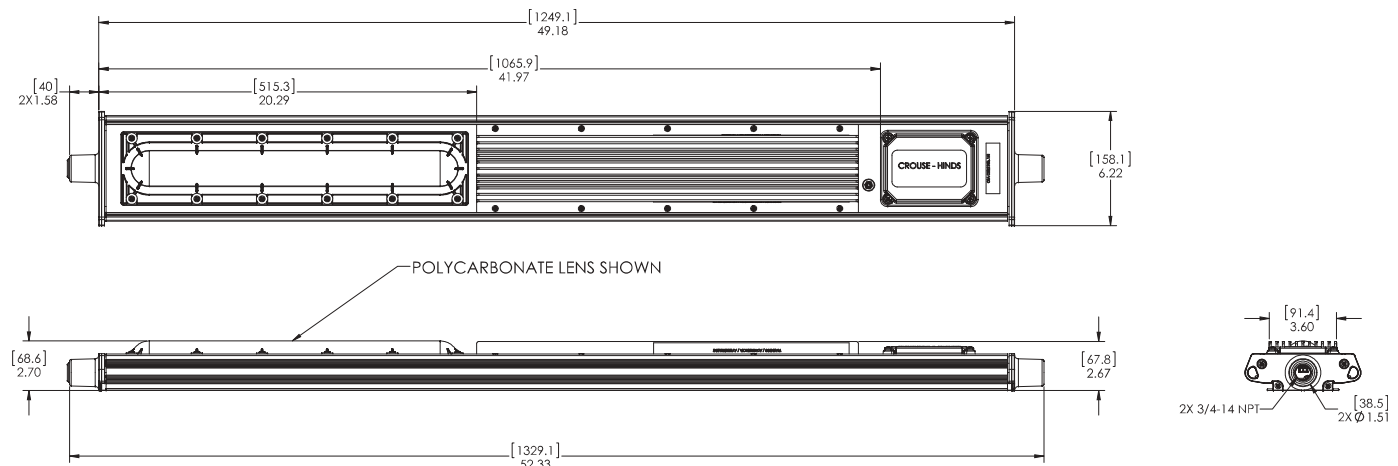

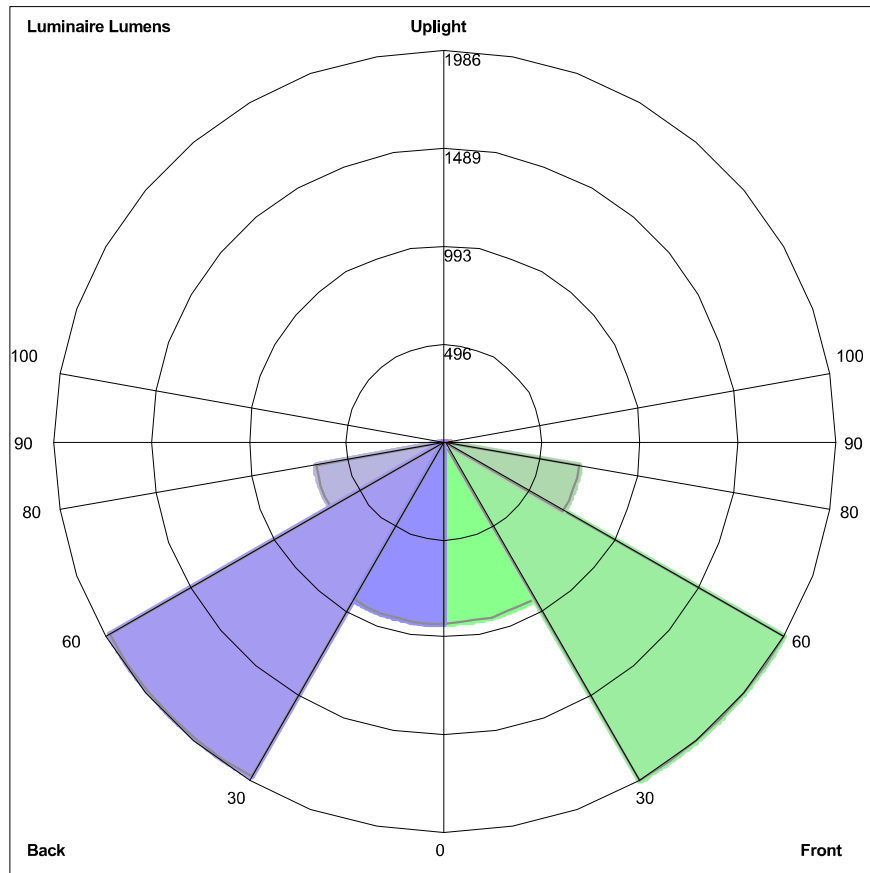

Luminaire Lumens:
 Front: Low=921.0, Medium=1985.6, High=698.7, Very High=29.2
 Back: Low=925.1, Medium=1963.4, High=664.7, Very High=26.5
 Uplight: Low=4.7, High=1.2

BUG Rating : B2-U1-G1

FIXTURE CUT SHEET

TYPE D



Dialight® LED High Bay & Low Bay

Technical Specification Sheet - Americas

Vigilant® LED High Bay - UL / CSA

Corded Model & Integrated Wiring Box Model

Corded Model



Mechanical Information:

Fixture weight:

18 lbs (8,16kg)

Shipping weight:

24 lbs (10,8kg)

Mounting:

3/4" NPT - top
Various Kits

Power Cord:

10' 18 AWG STOOW

Patent pending

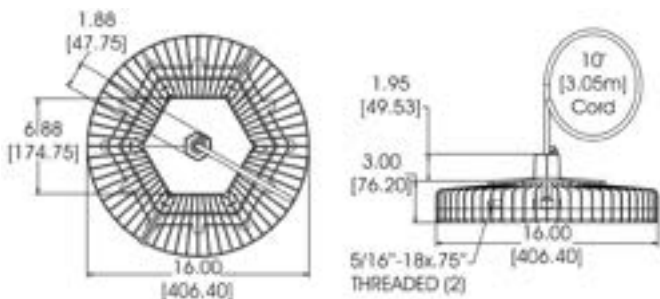

Integrated Wiring Box Model



Mechanical Information:

Fixture weight:

20 lbs (9 kg)

Shipping weight:

26 lbs (12 kg)

Mounting:

3/4" NPT or Hook

Wiring Box Cable Entries:

(2x) 3/4" NPT

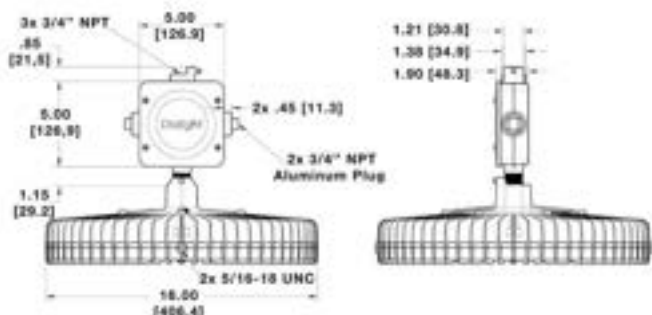

Dimensions in inches (mm)

WARNING - INSTALLATION & SECONDARY RETENTION. Use of any Dialight products without proper installation (including secondary retention / netting) and periodic inspections could cause severe injury or death. Dialight recommends that all installations should use secondary retention / netting (appropriate to the installation environment) where applicable. It is the exclusive responsibility of the contractor, installer and/or end-user to: (a) determine the suitability of the product for its intended application; and, (b) ensure that the product is safely installed (with secondary retention / netting where appropriate) and in compliance with all applicable laws and regulations. To the extent permissible under applicable laws, Dialight disclaims all liability for personal injury and/or other damage resulting from any dislodgment or other dislocation of its products.

Certifications & Ratings:

10 year warranty

UL 1598/A

UL 8750

IP66/67

CSA C22.2 No. 250.0-08

NEMA 4X

L70 rated for >150,000 hours

Variable Dimming:

Variable Dimming Control: 0-10 VDC

Dimming Range:

10 VDC = 100% light output

0 VDC = <10% light output

Occupancy Sensor:

Mounting Height:

Up to 40ft

Ingress Protection:

IP66

Electrical Specifications:

Operating Voltage:

100-277 VAC, 120-250 VDC
347-480 VAC

Total system power consumption:

See table

Operating Temp:

-40°F to +149°F (-40°C to +65°C)

Harmonics:

IEC 61000-3-2 Class C

Noise requirement /EMC:

FCC Title 47, Subpart B, Section 15, class A device. RF Immunity; 10V/m, 80MHz-1GHz

Transient protection:

100-277 VAC models tested to withstand up to 8kV/4kA per IEEE C62.41.
347-480 VAC models tested to withstand up to 6kV/3kA per IEEE C62.41

THD:

<20%

Power Factor:

>0.9

Fusing:

Internal

Construction:

Housing:

Copper free aluminum

Finish:

Superior dual coat finish
Sealed polyester topcoat
Chemical-resistant epoxy primer

Lens:

See table

Photometric Information:

CRI:

80

CCT:

5000K (cool white)
4000K (neutral white)

All values typical unless otherwise stated (tolerance +/- 10%)

Vigilant® LED High Bay - UL / CSA

Corded & Integrated Wiring Box



Project Information	
Part Number:	
Project:	
Fixture Type:	Date:

Specifications

Ordering Information

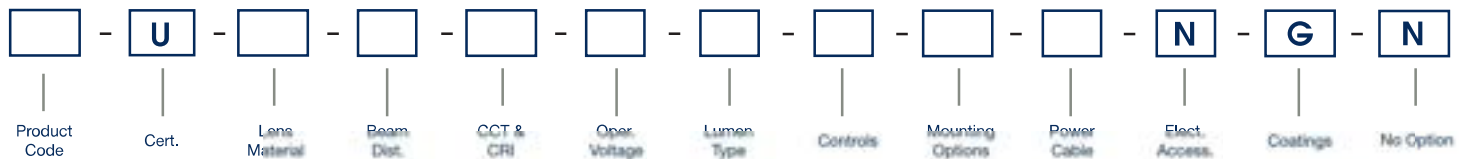

Product Code	Beam Distribution	Lumen Type	Power Cable
HC High Bay Integrated Pendant Wiring Box	E Oval	A 11,600 Lumens	N No Cord (HC only)
HE High Bay 3/4" NPT	M Medium	B 14,900 Lumens	W 10' [3 meter] Power Cable (HE only)
	N Narrow	C 19,800 Lumens	
	W Wide	E 27,500 Lumens	
Certification	CCT & CRI	Controls	Electrical Accessories
U UL 1506/A, CSA	C Cool White 5000K - 80 CRI	D Dimming (0-10V)	N No Plug
	N Neutral White 4000K - 80 CRI	N No Dimming (HE only)	
		M Occupancy Sensor (HC only)	
Lens Material	Operating Voltage	Mounting Options	Coatings
2 Acrylic - Clear (dry location only)	2 100-277 VAC / 120-250 VDC	H Hook	G Gray (RAL 7040)
4 Polycarbonate - Clear	5 347-480 VAC	N Pendant 3/4" NPT	
7 Glass - Clear		P Pendant 3/4" NPT with Safety Retention Tabs	
L Polycarbonate Dome - Diffused		R Safety Retention Tabs with Hook	
R Power Wash Glass, Clear			Option
			N No Option

- Notes**
- 1) Lumen type based on using a glass lens. See tables for lumens when changing lenses.
 - 2) When ordering occupancy sensor, use prefix HC.
 - 3) When ordering option HC, Controls = (D) Dimming or (M) Occupancy Sensor.

DISCLAIMER. All product information provided is, to the best of Dialight's knowledge, accurate as of the date of publication. When ordering, refer to www.dialight.com for current versions of: (a) relevant product documentation (including the relevant product data sheets); (b) Dialight terms and conditions of sale; and, (c) the relevant product warranty. To the extent that any contract is deemed formed between Dialight and the purchaser of Dialight products and/or an end-user, versions of documents available at www.dialight.com as at the date of sale shall be the versions incorporated therein. In the event of any discrepancy between this document or information provided at www.dialight.com, the latter shall prevail.

Ordering Information

Vigilant® LED High Bay - Corded Model



Corded Model - 3/4" Conduit - 100-277 VAC / 120-250 VDC								
Part Number	Lumens	Wattage	lm/W	CCT	Lens	Beam Distribution	Hardware Options	Wiring
HEU-7MC2-ENNW-NGN	27,500	185	149	CW	Glass - Clear	Medium	Pendant 3/4" NPT	10' Power Cable
HEU-7MC2-ENPW-NGN	27,500	185	149	CW	Glass - Clear	Medium	Pendant 3/4" NPT with Safety Tabs	10' Power Cable
HEU-7MC2-EDNW-NGN	27,500	185	149	CW	Glass - Clear	Medium	Pendant 3/4" NPT	10' Power Cable
HEU-4MC2-ENNW-NGN	27,200	185	147	CW	Polycarbonate - Clear	Medium	Pendant 3/4" NPT	10' Power Cable
HEU-2MC2-ENNW-NGN	27,200	185	147	CW	Acrylic - Clear	Medium	Pendant 3/4" NPT	10' Power Cable
HEU-LMC2-ENNW-NGN	27,000	185	146	CW	Polycarbonate Dome - Diffused	Medium	Pendant 3/4" NPT	10' Power Cable
HEU-2WC2-ENNW-NGN	27,000	185	146	CW	Acrylic - Clear	Wide	Pendant 3/4" NPT	10' Power Cable
HEU-7MC2-CNNW-NGN	19,800	130	152	CW	Glass - Clear	Medium	Pendant 3/4" NPT	10' Power Cable
HEU-7MC2-CNPW-NGN	19,800	130	152	CW	Glass - Clear	Medium	Pendant 3/4" NPT with Safety Tabs	10' Power Cable
HEU-7MC2-CDNW-NGN	19,800	130	152	CW	Glass - Clear	Medium	Pendant 3/4" NPT	10' Power Cable
HEU-4MC2-CNNW-NGN	19,600	130	151	CW	Polycarbonate - Clear	Medium	Pendant 3/4" NPT	10' Power Cable
HEU-LMC2-CNNW-NGN	19,400	130	149	CW	Polycarbonate Dome - Diffused	Medium	Pendant 3/4" NPT	10' Power Cable
HEU-7MN2-CNNW-NGN	19,400	130	149	NW	Glass - Clear	Medium	Pendant 3/4" NPT	10' Power Cable
HEU-7MC2-BNNW-NGN	14,900	100	149	CW	Glass - Clear	Medium	Pendant 3/4" NPT	10' Power Cable
HEU-4MC2-BNNW-NGN	14,800	100	148	CW	Polycarbonate - Clear	Medium	Pendant 3/4" NPT	10' Power Cable
HEU-LMC2-BNPW-NGN	14,600	100	146	CW	Polycarbonate Dome - Diffused	Medium	Pendant 3/4" NPT with Safety Tabs	10' Power Cable
HEU-LMC2-BNNW-NGN	14,600	100	146	CW	Polycarbonate Dome - Diffused	Medium	Pendant 3/4" NPT	10' Power Cable
HEU-7MC2-ANNW-NGN	11,500	80	145	CW	Glass - Clear	Medium	Pendant 3/4" NPT	10' Power Cable
HEU-4MC2-ANNW-NGN	11,500	80	144	CW	Polycarbonate - Clear	Medium	Pendant 3/4" NPT	10' Power Cable
HEU-2MC2-ANNW-NGN	11,500	80	144	CW	Acrylic - Clear	Medium	Pendant 3/4" NPT	10' Power Cable
HEU-LMC2-ANNW-NGN	11,400	80	143	CW	Polycarbonate Dome - Diffused	Medium	Pendant 3/4" NPT	10' Power Cable
Corded Model - 3/4" Conduit - 347-480 VAC								
HEU-7MC5-EDNW-NGN	27,500	185	149	CW	Glass - Clear	Medium	Pendant 3/4" NPT	10' Power Cable
HEU-7MC5-ENNW-NGN	27,500	185	149	CW	Glass - Clear	Medium	Pendant 3/4" NPT	10' Power Cable
HEU-7MC5-ENPW-NGN	27,500	185	149	CW	Glass - Clear	Medium	Pendant 3/4" NPT with Safety Tabs	10' Power Cable
HEU-4MC5-ENPW-NGN	27,200	185	147	CW	Polycarbonate - Clear	Medium	Pendant 3/4" NPT with Safety Tabs	10' Power Cable
HEU-7WC5-ENPW-NGN	27,200	185	147	CW	Glass - Clear	Wide	Pendant 3/4" NPT with Safety Tabs	10' Power Cable
HEU-7EC5-ENNW-NGN	25,900	185	140	CW	Glass - Clear	Oval	Pendant 3/4" NPT	10' Power Cable
HCU-4EC5-EMNW-NGN	25,600	185	138	CW	Polycarbonate - Clear	Oval	Pendant 3/4" NPT	10' Power Cable
HEU-7MC5-CDNW-NGN	19,800	130	152	CW	Glass - Clear	Medium	Pendant 3/4" NPT	10' Power Cable
HEU-7MC5-CNHW-NGN	19,800	130	152	CW	Glass - Clear	Medium	Hook	10' Power Cable
HEU-7MC5-CNNW-NGN	19,800	130	152	CW	Glass - Clear	Medium	Pendant 3/4" NPT	10' Power Cable
HEU-LMC5-CNNW-NGN	19,400	130	149	CW	Polycarbonate Dome - Diffused	Medium	Pendant 3/4" NPT	10' Power Cable
HEU-7MC5-BNNW-NGN	14,900	100	149	CW	Glass - Clear	Medium	Pendant 3/4" NPT	10' Power Cable
HEU-7MC5-ADNW-NGN	11,600	80	145	CW	Glass - Clear	Medium	Pendant 3/4" NPT	10' Power Cable
HEU-7MC5-ANNW-NGN	11,600	80	145	CW	Glass - Clear	Medium	Pendant 3/4" NPT	10' Power Cable
HEU-4MC5-ADNW-NGN	11,500	80	144	CW	Polycarbonate - Clear	Medium	Pendant 3/4" NPT	10' Power Cable
HEU-LMC5-ANNW-NGN	11,400	80	143	CW	Polycarbonate Dome - Diffused	Medium	Pendant 3/4" NPT	10' Power Cable

All values typical unless otherwise stated (tolerance +/- 10%)
 0-10V dimming option available for products in the above table. Replace the ninth character **N** with **D**. Ex: HEU-7MC2-ENNW-NGN becomes HEU-7MC2-EDNW-NGN.
 Acrylic lens is dry location only.

DISCLAIMER. All product information provided is, to the best of Dialight's knowledge, accurate as of the date of publication. When ordering, refer to www.dialight.com for current versions of: (a) relevant product documentation (including the relevant product data sheets); (b) Dialight terms and conditions of sale; and, (c) the relevant product warranty. To the extent that any contract is deemed formed between Dialight and the purchaser of Dialight products and/or an end-user, versions of documents available at www.dialight.com as at the date of sale shall be the versions incorporated therein. In the event of any discrepancy between this document or information provided at www.dialight.com, the latter shall prevail.

LUMINAIRE CLASSIFICATION SYSTEM (LCS) GRAPH

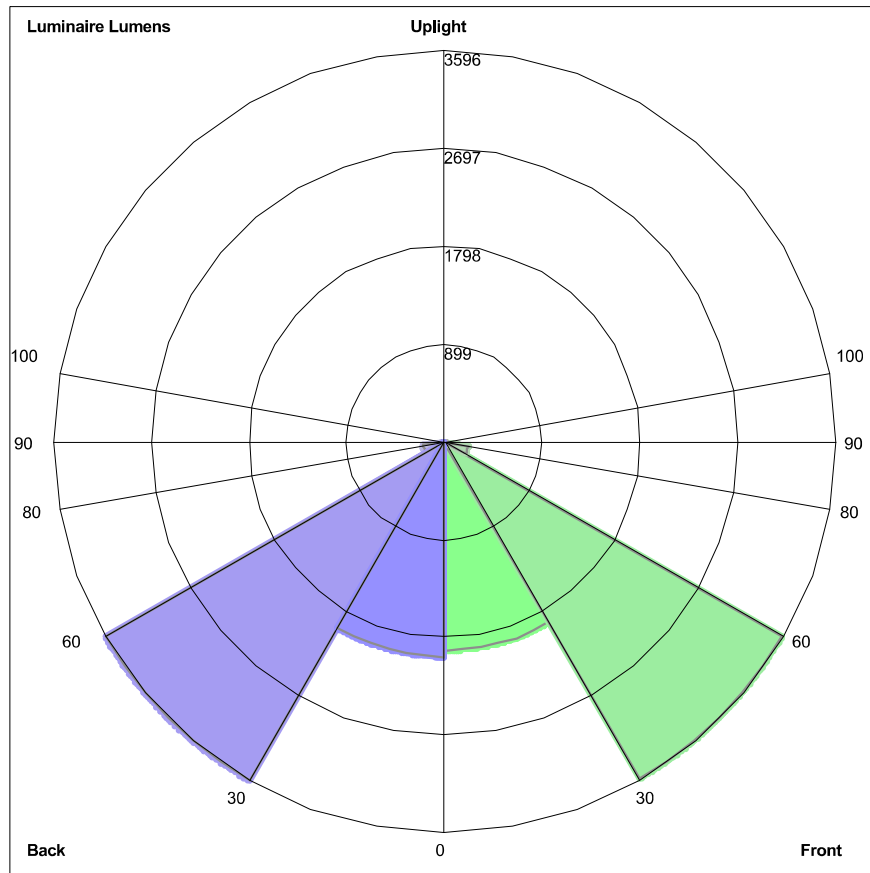

Luminaire Lumens:
Front: Low=1920.3, Medium=3580.5, High=221.0, Very High=4.4
Back: Low=1974.5, Medium=3596.1, High=199.5, Very High=3.8
Uplight: Low=0.0, High=0.0

BUG Rating : B3-U0-G0

FIXTURE CUT SHEET

TYPE E

Pauluhn DFL HID hazardous area floodlights

Cl. I, Div. 2, Groups A, B, C, D
Cl. I, Zone 2, AEx nR II
Cl. II, Div. 1, Groups F, G (250W
max.)
Ex nR II

Marine & Wet Locations
NEMA 4X
IP66

6L

Applications:

- Onshore drilling and exploration
- Pipeline compressor and storage
- Corrosive environments
- Façade security lighting

Features:

- 150-400W high pressure sodium or 175-400W metal halide
- AEx nR, Ex nR restricted breathing rating is standard – restricted breathing offers cooler T-numbers for increased hazardous locations suitability
- NEMA 7x6 butterfly beam floodlight pattern – wide, uniform and far reaching to provide excellent efficiency and more light where you need it
- NEMA Type 4X and IP66 heavy duty, die cast copper-free aluminum construction is designed for use indoors and outdoors in marine and wet locations with stainless steel external hardware suitable for saltwater and corrosive applications
- 40°C, 55°C and 65°C ambient suitability – addresses high ambient common at industrial facilities
- Low ambient capability to -40°C – perfect for colder climates
- Hinged door frame assembly – has captive cover screws for ease of relamping
- Yoke mount design – standard construction provides the greatest mounting flexibility; can be mounted vertically (wall), horizontally (rooftop or floor) or any angle in between
- 3-axis resonance withstand and UL844 vibration compliant – can stand up to the tough jobs
- Precision formed aluminum reflector – superior beam control, distribution and efficiency
- High light output with a low cost of operation – cost-effectiveness in a high wattage floodlight
- Slipfitter adapter for pole mounting and wall mounting bracket available

Certifications and compliances:

- Class I, Division 2, Groups A, B, C, D
- Class I, Zone 2, AEx nR II
- Class II, Division 1, Groups F, G (250W maximum)
- Ex nR II
- UL/cUL844 – Hazardous Locations
- UL/cUL1598 – Luminaires
- UL/cUL1598A – Supplemental Requirements for Luminaires for Installation on Marine Vessels
- 60079-15
- NEMA Type 4X
- IP66
- Marine and wet locations
- ABS



Standard materials and finishes:

- Housing and lens frame – heavy duty die cast copper-free aluminum with Corro-free epoxy powder coat finish
- Lens – heat- and impact-resistant tempered glass
- Gasket – one-piece silicone
- Mounting brackets – aluminum with Corro-free epoxy powder coat finish
- Reflector – precision formed aluminum
- Lamp holder – porcelain
- Hardware – stainless steel

Technical specifications:

- Entries – one 3/4" AEx/Ex gland
- Wind rating – EPA: 2.90 at vertical
- Lamp type – high pressure sodium; probe start metal halide^A; pulse start metal halide (lamps not provided)
- Lamp holder – mogul base
- Ballast – multi-tap 120/208/240/277V, 60 Hz (standard); 220-240V, 50 Hz (optional); tri-tap 120/277/347V (optional); 480V (optional)

Mounting option:

- Yoke mount

Photometrics:

- Complete photometrics can be found at www.crouse-hinds.com/photometrics

^ANot available in the U.S.

Pauluhn DFL HID hazardous area floodlights

Cl. I, Div. 2, Groups A, B, C, D
Cl. I, Zone 2, AEx nR II
Cl. II, Div. 1, Groups F, G (250W max.)
Ex nR II

Marine & Wet Locations
NEMA 4X
IP66

6L

Options:

Description	Suffix
• Lamps included	L Ⓟ
• 480V.....	480
<i>Replace /MT in catalog number with /480</i>	
• 230V.....	230
<i>Replace /220 ONLY in catalog number with /230</i>	

Accessories (ordered separately):

Description	Cat. #
• Pole mount slipfitter adapter.....	SFA6
• Wall mount bracket adapter.....	SWB6
• Bull horn, 2 tenon, gray.....	BLHN2
• Bull horn, 3 tenon, gray.....	BLHN3

Ordering information:

Cat. #	Lamp type	Watts	Weight (lbs.)	ANSI lamp type	Zone T-code	Division T-code	Ambient temperature °C	Supply wire °C
DFLMY250/MT 76 S828	Pulse start metal halide	250	42.0	M153	T3	T1	40/55/65	90/90/105
DFLMY400/MT 76 S828	Pulse start metal halide	400	44.0	M155	T3	T1	40/55	105/105
DFLMY320/MT 76 S828	Pulse start metal halide	320	44.0	M154	T3	T1	40/55	105/105
DFLMY250/TT 76Ⓢ	Probe start metal halide	250	42.0	M58Ⓢ	T3	T1	40/55/65	90/90/105
DFLMY400/TT 76Ⓢ	Probe start metal halide	400	44.0	M59Ⓢ	T3	T1	40/55	90/105
DFLMY250/220 50 76Ⓢ	Probe start metal halide	250	42.0	M58Ⓢ	T3	T1	40/55/65	90/90/105
DFLMY400/220 50 76Ⓢ	Probe start metal halide	400	44.0	M59Ⓢ	T3	T1	40/55	90/105
DFLSY250/MT 76	High pressure sodium	250	40.0	S50	T3	T1	40/55/65	90/90/105
DFLSY400/MT 76	High pressure sodium	400	44.0	S51	T3	T1	40/55	90/105
DFLSY250/TT 76	High pressure sodium	250	40.0	S50	T3	T1	40/55/65	90/90/105
DFLSY400/TT 76	High pressure sodium	400	44.0	S51	T3	T1	40/55	90/105
DFLSY250/220 50 76	High pressure sodium	250	40.0	S50	T3	T1	40/55/65	90/90/105
DFLSY400/220 50 76	High pressure sodium	400	44.0	S51	T3	T1	40/55	90/105

Dimensions (in inches):

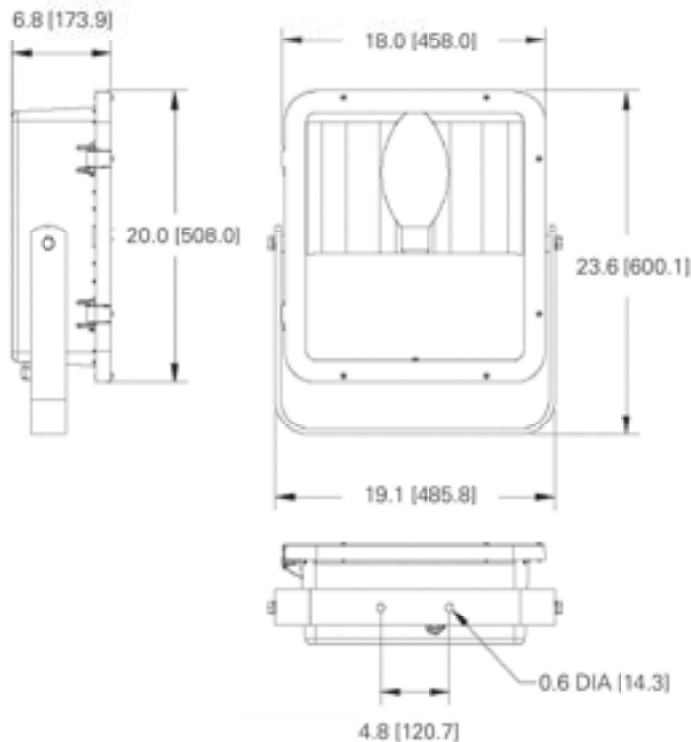

Bull horns – provided with 2 3/8" pole tenon

Ⓢ Lamp is not included unless option 'L' is selected.
Ⓢ Not available in the U.S.

6L

LUMINAIRE CLASSIFICATION SYSTEM (LCS) GRAPH

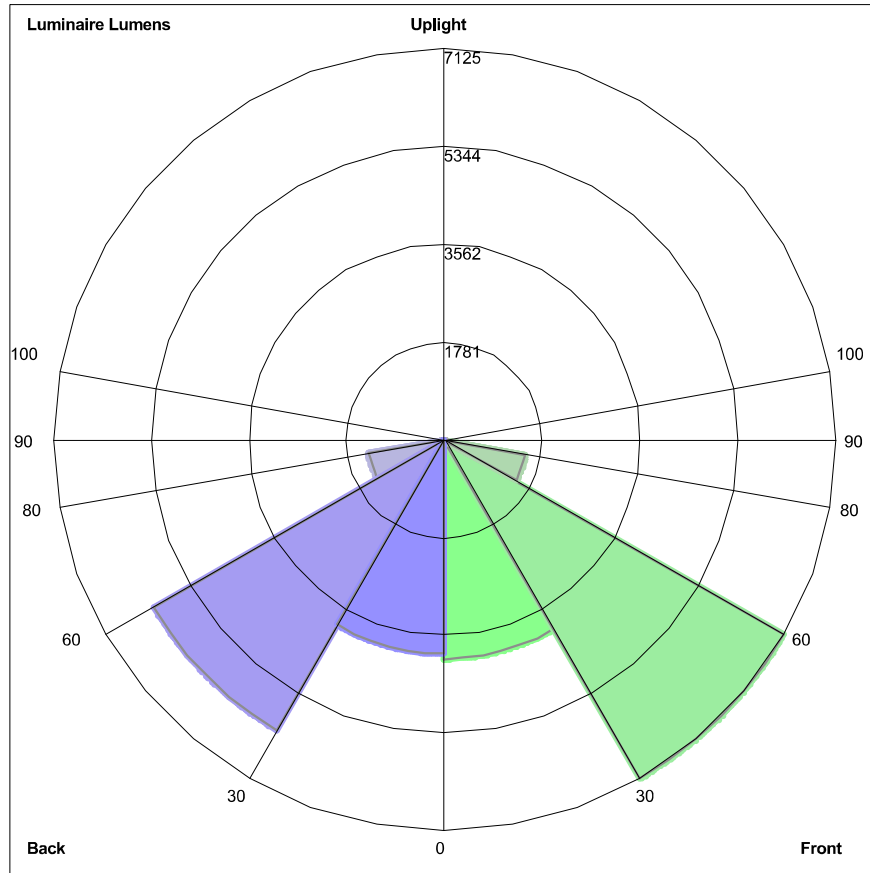

Luminaire Lumens:
Front: Low=3985.6, Medium= 7125.0, High=1500.3, Very High=28.6
Back: Low=3894.8, Medium=6102.1, High=1404.5, Very High=40.2
Uplight: Low=0.0, High=0.0

BUG Rating : B4-U0-G3

FIXTURE CUT SHEET

TYPE F

Pauluhn DLL LED Luminaires

For land-based drilling

Cl. I, Div. 2, Groups A, B, C, D
Cl. I, Zone 2
Cl. II, Div. 2, Groups F, G
Cl. III

UL Listed
CSA Certified
Marine & Wet Locations
NEMA 4X; IP66

2L

2L

The Pauluhn™ DLL linear LED is specifically designed to replace fluorescent T12, T8 and T5HO lighting on land-based and offshore drilling platforms. The rugged and durable design features the industry's most versatile and flexible mounting options. The Pauluhn DLL is the ideal solution for high vibration, impact and hose down in drilling applications.

Model	Typical lumens	Watts	Lumens per watt	Equivalent HID luminaire	Typical energy savings / lifetime
DLL2	3,958	32	124	T12HO	Up to 63%
				T8HO	Up to 59%
				T5HO	Up to 47%
				T12	Up to 36%
				T8	Up to 25%
DLL4	7,900	63	130	T5	Up to 9%
				T12HO	Up to 58%
				T8HO	Up to 54%
				T5HO	Up to 43%
				T12	Up to 37%
				T8	Up to 22%
				T5	Up to 10%

Applications:

- Land-based and offshore rigs; areas include: derrick, mast, SCR house, top drive, operator's house, power and pump stations

Features:

- High efficacy: up to 120 LPW
- 40°C to +65°C ambient operating temperature (standard model)
- Low profile (<3" height)
- Versatile ceiling/swivel, wall, flush, pole and pendant mounting options
- Wide and narrow optics for uniform illumination in control room and drill mast
- Four points of secondary retention
- 2,000 PSI high pressure hose rated
- High vibration resistance
- Emergency battery back-up (90 minutes) and surge protection options (up to 10 kV) [Ⓐ]
- DesignLights Consortium® Qualified (some models are not DLC qualified) [Ⓑ]
- 5 year fixture warranty

Standard materials:

- Housing – copper-free aluminum; Corro-free epoxy powder coat (optional)
- Lens – clear polycarbonate; diffused polycarbonate

Photometrics:

- Complete photometrics can be found at www.crouse-hinds.com/photometrics

Temperature performance data:

Ambient temp. °C	Min. temp. supply wire °C	Simultaneous rating		
		Class I, Div. 2	Class II, Div. 2	Class I, Div. 2; Class II, Div. 2
40	60	T6	T6	T6
55	75	T5	T5	T5
65	90	T5	T5	T5



Mounting (ordered separately):

Versatile mounting options:

- Flush back mount
- Swivel/ceiling back mount
- Offset ceiling mount
- Offset wall mount
- Pole mount
- Pendant mount

Easily retrofit to:

- Existing Pauluhn DuraPro and MagnaPro fluorescent light fixtures
- Rig-A-Lite and Snelson C1D2 fluorescent lighting fixtures

Certifications and compliances:

NEC:

- Class I, Division 2, Groups A, B, C, D
- Class I, Zone 2
- Class II, Division 2, Groups F, G
- Class III
- NEMA 4X, IP66
- Marine and wet locations

UL standards:

- UL844 – Electrical Fixture Hangers for Hazardous Locations
- UL1598 – Luminaire
- UL1598A – Luminaire for Installation on Marine Vessels
- UL924 – Emergency Lighting

CSA standard:

- C22.2 No. 137

Additional certifications:

- ABS design assessed

Electrical ratings:

	DLL2	DLL4
Lumen output	3,958	7,900
Frequency	50/60 Hz	50/60 Hz
Voltage	100-277 VAC, 108-250 VDC; 347-480 VAC	

Model	Voltage	Current (A)	Watts	Power factor	THD
DLL2/UNV1	100	0.33	32.5	0.92	<20%
DLL2/UNV34	347	0.10	32.2	0.92	<20%
DLL2/UNV34	480	0.07	34.5	0.92	<20%
DLL4/UNV1	100	0.63	63.4	0.92	<20%
DLL4/UNV1	277	0.23	62.5	0.92	<20%
DLL4/UNV34	347	0.18	61.4	0.92	<20%
DLL4/UNV34	480	0.13	63.9	0.92	<20%

Weights:

Model	Lbs.	Kg.
DLL2	12.50	5.70
DLL4	22.50	10.20

[Ⓐ] One year warranty.

[Ⓑ] Refer to www.designlights.org Qualified Products List under Family Models for full listing details. Not all models are approved for all application categories.

Pauluhn DLL LED luminaires

For land-based drilling

Cl. I, Div. 2, Groups A, B, C, D
Cl. I, Zone 2
Cl. II, Div. 2, Groups F, G
Cl. III

UL Listed
CSA Certified
Marine & Wet Locations
NEMA 4X; IP66

2L

2L

Designed for drilling. Pauluhn DLL linear LED luminaires are engineered to handle demanding conditions faced on land-based drilling rigs. The DLL stands up to high vibration, hose down, shock and impact, while delivering long life and high lumen performance for up to 20 years.

Custom optics:

- Standard wide (120°) beam spread for control room and indoor application maximizes illumination on wall panels
- Narrow (80°) beam spread option for high mast/derrick application avoids spillage and light loss

Comprehensive certification:

- Single model certified for use in Class I, Division 2 and Class II, Division 2 harsh and hazardous applications

Quick & easy installation:

- Easy access to drivers and wiring
- No custom brackets or hardware needed
- Seven mounting options available
- Easily retrofit to Pauluhn DuraPro and MagnaPro, Rig-A-Lite and Snelson



Slim profile:

- 2.7" fixture height (excluding mounting brackets)
- Perfect for mounting in confined or low height areas

Built to last:

- Ingress protection from hose down water or diesel fuel in harsh operational conditions – passed 2,000 PSI high pressure test
- Vibration-, impact- and shock-resistant – passed 5G, 3-axis vibration test
- 60,000 hour lifetime at 55°C ambient



Pauluhn DLL LED Luminaires

For land-based drilling

Cl. I, Div. 2, Groups A, B, C, D
Cl. I, Zone 2
Cl. II, Div. 2, Groups F, G
Cl. III

UL Listed
CSA Certified
Marine & Wet Locations
NEMA 4X; IP66

2L

2L

Ordering information:

Part number example

DLL4N/UNV1 S903 TF P EM1

DLL	4	N	/UNV1	S903	TF	P	EM1
Series	Optics	Lens	Options	Emergency back-up			
DLL Pauluhn DLL linear LED luminaire	BLANK Wide (120°) N Narrow (80°)	S903 Clear polycarbonate S903D Diffused polycarbonate	TF Pull wire included in fixture	BLANK Standard model (no battery back-up) EM1Ⓞ Integrated emergency battery back-up EM Remote emergency kit			
Length / lumens	Voltage	Finish					
4 4 ft. length, 7,900 lumens 2 2 ft. length, 3,958 lumens	/UNV1 100-277 VAC, 108-250 VDC /UNV34 347-480 VAC	BLANK Natural aluminum P Painted (gray, epoxy) WH Painted (white, epoxy)					

Accessories (ordered separately):

Description	Cat. #	Description	Cat. #
• Flush/back mount back plate.....	DP1057MTK <i>Compatible with DuraPro</i>	• Pendant mount kit.....	PEND HAZ KIT
• Ceiling/swivel mount.....	DP1050MTK <i>Compatible with DuraPro</i>	• Safety chain kit.....	SS KIT
• Ceiling/wall mount offset.....	DP1053MTK <i>Compatible with DuraPro</i>	• 1 amp driver replacement kit, 100-277 VAC for 4 ft. linear.....	VMVL/UNV1 80W 1A KIT
• Ceiling mount bracket and adapter kit.....	MP1054MTK KIT <i>Compatible with MagnaPro</i>	• 1 amp driver replacement kit, 347-480 VAC for 4 ft. linear.....	VMVL/UNV34 80W 1A KIT
• Offset wall mount.....	DP1052MTK <i>Compatible with DuraPro</i>	• 0.5 amp driver replacement kit, 100-277 VAC for 2 ft. linear.....	VMVL/UNV1 80W 0.5A KIT
• Pole mount kit, 1.25" conduit.....	PM KIT 1.25	• 0.5 amp driver replacement kit, 347-480 VAC for 2 ft. linear.....	VMVL/UNV34 80W 0.5A KIT
• Pole mount kit, 1.50" conduit.....	PM KIT 1.5		
• Pole mount kit, 2.00" conduit.....	PM KIT 2.0		

Dimensions and mounting options:

Technical drawings showing dimensions for DLL4 and DLL2 luminaires. Dimensions are provided in inches and millimeters.

DLL4 Dimensions: Length 1329.1 mm (52.33"), End cap diameter 68.58 mm (2.70"), Mounting hole diameter 157.9 mm (6.22").

DLL2 Dimensions: Length 719.6 mm (28.33"), End cap diameter 68.58 mm (2.70").

Mounting Options:

- Offset wall: DP1052MTK
- Flush ceiling: DP1057MTK
- Offset ceiling: DP1053MTK
- Ceiling/swivel: DP1050MTK
- Ceiling and adapter: MP1054MTK KIT
- Pole mount: PM KIT 1.25/1.5/2.0
- Pendant mount: PEND HAZ KIT

Ⓞ One year warranty. Remote EM kit also available, 120-277 VAC only. Available with 4 ft. model only.

LUMINAIRE CLASSIFICATION SYSTEM (LCS) GRAPH

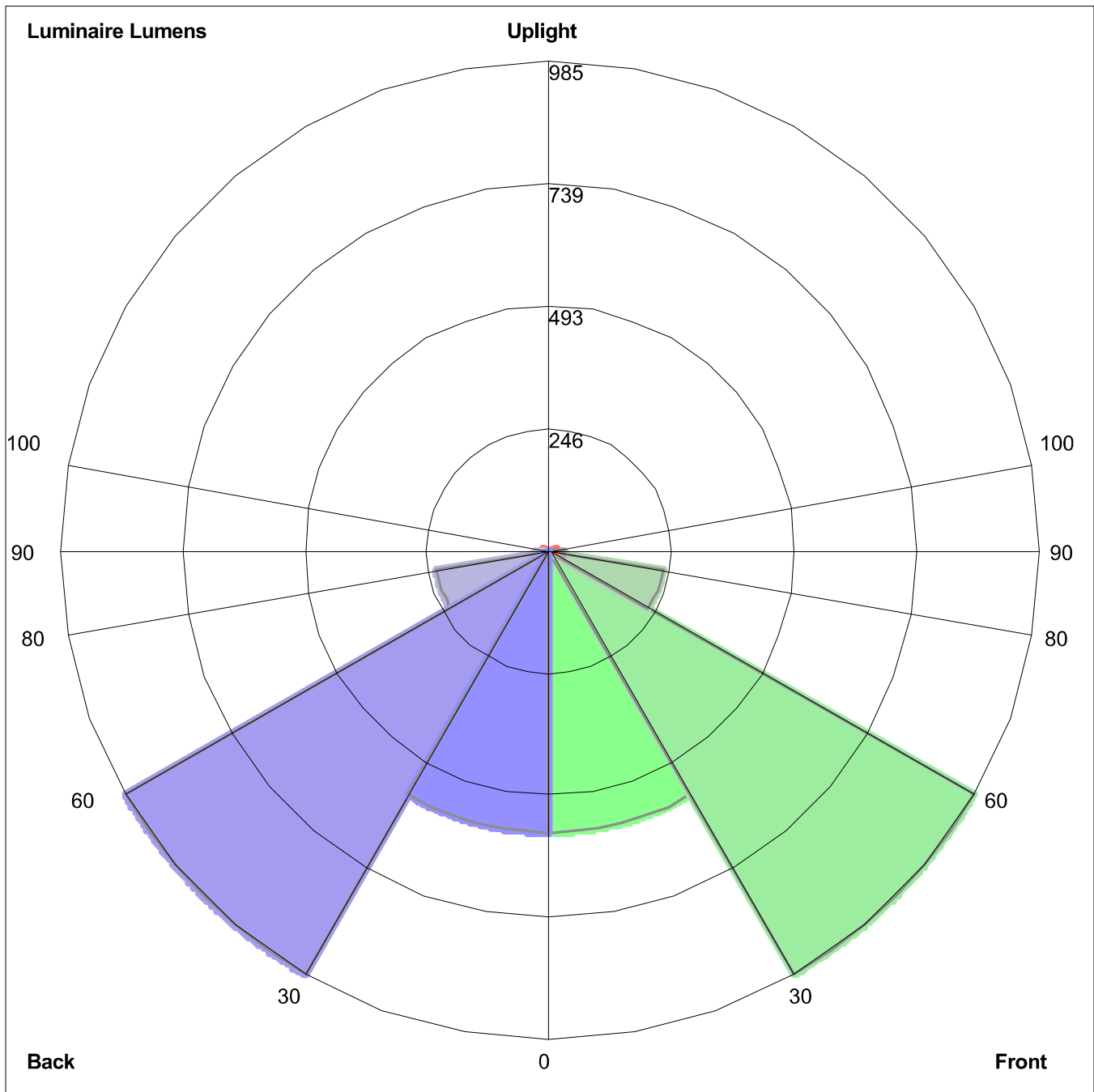

Luminaire Lumens:
Front: Low=568.6, Medium=985.4, High=230.6, Very High=28.4
Back: Low=568.6, Medium=985.4, High=230.6, Very High=28.4
Uplight: Low=12.8, High=0.3

BUG Rating : B2-U2-G1

FIXTURE CUT SHEET

TYPE G



Ultra high output, high efficiency LED floodlight with NEMA Types: 7H x 6V, 6H x 4V, 4H x 6V, 5H x 5V and 3H x 3V. patent-pending "Air-Flow" technology ensures long LED and driver lifespan. Use for general and security lighting for large areas, building façades, signs and landscapes.

Color: Bronze

Weight: 66.1 lbs

Project:

Type:

Prepared By:

Date:

Driver Info

Type	Constant Current
120V	2.65A
208V	1.59A
240V	1.38A
277V	1.17A
Input Watts	325.9W

LED Info

Watts	300W
Color Temp	5000K (Cool)
Color Accuracy	72 CRI
L70 Lifespan	100,000 Hours
Lumens	45,171
Efficacy	138.6 lm/W

Technical Specifications

Compliance

UL Listed:

Suitable for wet locations. Suitable for ground mounting.

IESNA LM-79 & LM-80 Testing:

RAB LED luminaires and LED components have been tested by an independent laboratory in accordance with IESNA LM-79 and LM-80.

DLC Listed:

This product is listed by Design Lights Consortium (DLC) as an ultra-efficient premium product that qualifies for the highest tier of rebates from DLC Member Utilities. DLC Product Code: PF5PMFXJ

Optical

NEMA Type:

NEMA Beam Spread of 7H x 6V

Performance

Lifespan:

100,000-Hour LED lifespan based on IES LM-80 results and TM-21 calculations

Construction

IP Rating:

Ingress Protection rating of IP66 for dust and water

Maximum Ambient Temperature:

Suitable for use in up to 40°C (104°F)

Effective Projected Area:

EPA = 4

Cold Weather Starting:

Minimum starting temperature is -40°C (-40°F)

Thermal Management:

Superior thermal management with external "Air-Flow" fins

Lens:

Tempered glass lens

Housing:

Die-cast aluminum housing and door frame

Mounting:

Heavy-duty slipfitter for 2 3/8"OD pipe

Reflector:

Specular and semi-specular vacuum-metalized polycarbonate

Technical Specifications (continued)

Construction

Gaskets:

High-temperature silicone gaskets

Finish:

Formulated for high durability and long-lasting color

Green Technology:

Mercury and UV free. RoHS-compliant components.

Tilt Increment:

Rotates in 6 degree increments

LED Characteristics

LEDs:

Multip-chip, high-output, long-life LEDs

Color Consistency:

7-step MacAdam Ellipse binning to achieve consistent fixture-to-fixture color

Color Stability:

LED color temperature is warranted to shift no more than 200K in color temperature over a 5-year period

Color Uniformity:

RAB's range of Correlated Color Temperature follows the guidelines of the American National Standard for Specifications for the Chromaticity of Solid State Lighting (SSL) Products, ANSI C78.377-2017.

Electrical

Drivers:

Constant Current, 1050mA, 50/60 Hz, 120-277V, 4 kV surge protection, 120V: 2.65A, 208V: 1.59A, 240V: 1.38A, 277V: 1.17A, THD <20%, Power Factor: 99%

THD:

9.26% at 120V, 12.56% at 277V

Power Factor:

99.3% at 120V, 96.6% at 277V

Note:

All values are typical (tolerance +/- 10%)

Other

Equivalency:

Equivalent to 1000W Metal Halide

Warranty:

RAB warrants that our LED products will be free from defects in materials and workmanship for a period of five (5) years from the date of delivery to the end user, including coverage of light output, color stability, driver performance and fixture finish. RAB's warranty is subject to all terms and conditions found at rablighting.com/warranty.

Buy American Act Compliance:

RAB values USA manufacturing! Upon request, RAB may be able to manufacture this product to be compliant with the Buy American Act (BAA). Please contact customer service to request a quote for the product to be made BAA compliant.

Dimensions

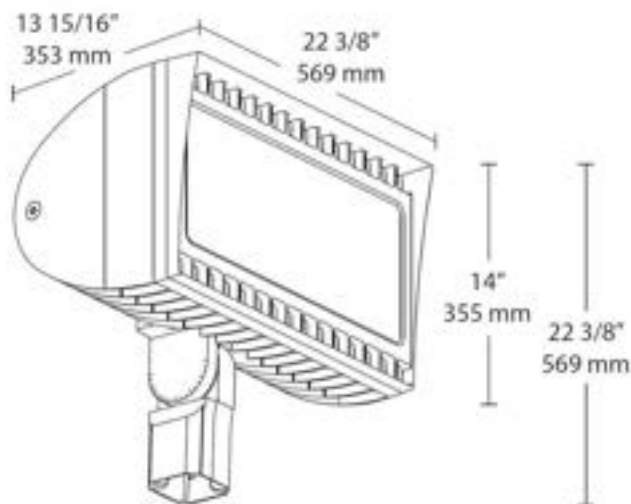

Features

- 300W replaces 1000 MH floodlights
- 100,000-hour LED lifespan
- 5-Year, No-Compromise Warranty

Ordering Matrix

Family	Wattage	Mounting	Color Temp	NEMA Type	Finish	Driver Options	Options	Other Options
FXLED	300	SF						
	200 = 200W 300 = 300W	SF = Slipfitter T = Trunnion	Blank = 5000K (Cool) N = 4000K (Neutral) Y = 3000K (Warm)	Blank = 7H x 6V B64 = 6H x 4V B55 = 5H x 5V B33 = 3H x 3V B46 = 4H x 6V	Blank = Bronze W = White	Blank = 120-277V /480 = 480V /BL = Bi-Level (Slipfitters only) ¹ /D10 = 0-10V Dimming	Blank = No option /PCS = 120V Swivel /PCS2 = 277V Swivel /PCT = 120-277V Twistlock /PCT4 = 480V Twistlock /PCS4 = 480V Swivel /LC = Lightcloud® Controller	USA = BAA Compliant Blank = Standard

¹ Slipfitter models only

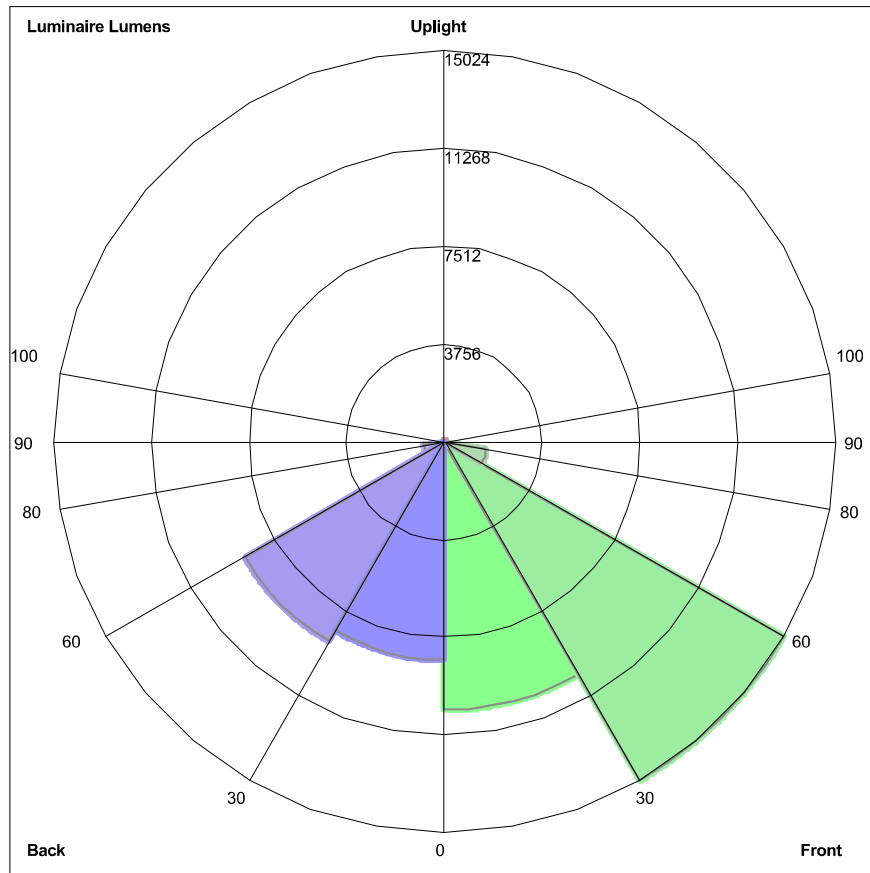

Luminaire Lumens:
 Front: Low=10319.6, Medium=15024.4, High=1636.8, Very High=9.1
 Back: Low= 8373.0, Medium=8865.3, High=802.5, Very High=9.9
 Uplight: Low=0.9, High=61.0

BUG Rating : B5-U3-G2

Fixture Cut Sheet

Type H

Contender™ LED Series Luminaires

Enclosed and Gasketed Fixtures — Hazardous Locations

NEC/CEC: Class I, Division 2, Groups A,B,C,D | Class I, Zone 2, AEx ec IIC Ⓢ | Class II, Division 1, Groups E,F,G | Zone 21, AEx tb IIC Ⓢ | Class II, Division 2, Groups F,G | Class III | Type 3R, 4, 4X | IP66/67 | Simultaneous Exposure | Suitable for Use in Wet Locations | Marine Outside Type (Salt Water) | American Bureau of Shipping (ABS) Certified | International Dark Sky (IDA) Approved

Applications

- Enclosed and gasketed fixtures suitable for use in:
 - A wide range of industrial, chemical processing and other areas where flammable gases, vapors and combustible dusts and fibers are present including simultaneous exposure
 - Marine and wet locations
 - Areas of low clearance, low ceiling heights or where fixture weights must be minimized
- Typical industries include:
 - Pulp and paper mills
 - Processing plants
 - Chemical plants
 - Petrochemical facilities
 - Oil refineries
 - Drilling rigs
 - Foundries
 - Waste treatment
 - Mining
 - Steel mills
- Typical applications include:
 - Walkways/catwalks
 - Stairwells
 - Grain elevators
 - Tunnels
 - Pipe racks
 - Offshore rigs
 - Vessel lighting
 - Cooling towers
 - Processing areas

Features

- Mounts directly to the following Crouse Hinds™ + Champ® + VMV mounting hoods.

Mounting Hoods	Model
Pendant	APM2, APM3
Flexible Pendant	HPM2
Ceiling	CM2, CM3
Wall	TWM2, TWM3
Quad	QM25
25° Stanchion	JM5
Straight Stanchion	PM5

- Compact light weight low profile design is suited for low mounting heights (less than 5.44 kg. [12 lbs]).
- Customize to the application requirements with four different field replaceable globe options: clear and diffused polycarbonate, clear glass, or prismatic glass refractor.
- Three Correlated Color Temperatures (CCTs) for a wide variety of applications: Cool (5000K), Neutral (4000K) and Warm (3000K)
- Three light output levels for retrofit of HID fixtures up to 175 W.

Nominal Lumens Ⓢ	HID Equivalent	Model
3300	70-100W	VMV3LCG5BU
4400	100-150W	VMV4LCG5BU
5500	150-175W	VMV5LCG5BU

Ⓢ Nominal Lumen value for 5000K CCT, clear glass globe. Detailed lumen information is provided in tables.

Ⓢ AEx rating is only applicable to product configurations with terminal block wiring option
 + Crouse-Hinds and Champ are registered trademarks of Cooper Crouse-Hinds.



With Clear Plastic Globe



With Short Prismatic Glass Refractor

- Standard 6 kV surge protection.
- Ambient Temperature: BU: -40 °C to +65 °C (-40 °F to +149 °F); BH: -40 °C up to +65 °C (-40 °F up to +149 °F).
- Heavy duty, high temperature silicone rubber gaskets.
- Reported L70 is >108,000.
- Field replaceable globes and IP66 rated LED driver.
- Rugged housing with superior thermal design translates to long luminaire life.
- Luminaire comes pre-wired with three conductors, approximately 304.8 mm (12" long), of 14 AWG TEW wire from the IP68 watertight NPT hub at the top of the luminaire lid.
- Product can be configured with wirenuts or screw terminal blocks for ease of wiring.
- Photometric data and electronic drawings available upon request.

Options

- Glass and Polycarbonate globe and glass refractor guards available, purchase separately.

Standard Materials

- Luminaire body: cast copperfree (4/10 of 1% max.) aluminum
- All hardware: stainless steel
- Globe: polycarbonate or glass
- Glass refractor guard: stainless steel wire
- Globe guard, short refractor guard and safety cable: stainless steel wire
- Reflector: fiberglass reinforced white polyester
- Visor: aluminum
- Gasket: silicone rubber

Standard Finishes

- Luminaire bodies, glass refractor guard and visor: gray epoxy powder coat finish, electrostatically applied for complete uniform protection

NEC/CEC Certifications and Compliances

- UL Standard: UL 50E, Second Edition; UL 844, Thirteenth Edition; UL 1598, Third Edition; UL 1598A, First Edition; UL 8750, Second Edition;
- CSA Standard: C22.2 No 0-10; C22.2 No. 94.2-15; C22.2 No. E60598-1:16; C22.2 No. 137-M1981; C22.2 No. 250.0-08; C22.2 No. 250.13-14; C22.2 No. 60529:16
- cCSAus Listed: Master contract 164460; Certificate Number 70170001

International Dark-Sky Association

- IDA Dark Sky Approved when ordering VMV[3L/4L/5L]W[P5/D5/G5]xxx with MMVISOR accessory (3000K CCT).

DesignLights™ Consortium

- Check DLC QPL for current list of products.

Contender™ LED Series Luminaires

Enclosed and Gasketed Fixtures — Hazardous Locations

NEC/CEC: Class I, Division 2, Groups A,B,C,D | Class I, Zone 2, AEx ec IIC Ⓞ | Class II, Division 1, Groups E,F,G | Zone 21, AEx tb IIC Ⓞ | Class II, Division 2, Groups F,G | Class III | Type 3R, 4, 4X | IP66/67 | Simultaneous Exposure | Suitable for Use in Wet Locations | Marine Outside Type (Salt Water) | American Bureau of Shipping (ABS) Certified | International Dark Sky (IDA) Approved

LED Luminaires | Area / Task | Hazardous Location | NEC / CEC

Illustrated Features

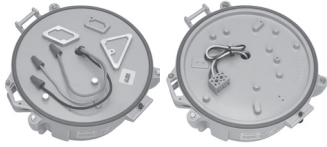

Wiring Flexibility

Choose between wire nuts and screw terminal blocks to suit end user wiring preferences. Terminal blocks support UL/CSA 24 to 12 AWG wire.



Globe Gaskets

Silicone rubber gaskets seal out moisture, dirt and dust. Stays flexible, withstands extreme temperatures. Closure design assures uniform gasket compression.



Watertight

Watertight IP68 rated bushing where cord enters luminaire hood ensures no water will enter the luminaire from the conduit through the mounting hood.



Prismatic Refractor

Heat-resistant refractor threads directly into fixture housing and seal against a high-temperature silicone rubber gasket.



Angled Reflector and Visor

Angled reflector is thick, tough fiberglass reinforced white polyester. Visor is aluminum with electrostatically applied, gray epoxy powder coat finish. Quickly attach either accessory to luminaire with furnished stainless steel screws.



“Safety” Cable

Safety cable option threads through the fixture housing for additional safety.

Heatsink: Reliable heat transfer via the cast, epoxy powder coat aluminum body. Provides maximum heat dissipation from the LED assembly to the outside environment.

Driver Assembly: IP66 rated driver utilizes non-sparking components avoiding the ignition of gases or vapors that may be present.

Electrical Protection: External Grounding provisions for additional safety.

Epoxy Finish: Fixture housing, hoods and guards are copperfree aluminum with triple protection epoxy powder coat finish.

Ⓞ AEx rating is only applicable to product configurations with terminal block wiring option

Contender™ LED Series Luminaires

Enclosed and Gasketed Fixtures — Hazardous Locations

NEC/CEC: Class I, Division 2, Groups A,B,C,D | Class I, Zone 2, AEx ec IIC Ⓢ | Class II, Division 1, Groups E,F,G | Zone 21, AEx tb IIC Ⓢ | Class II, Division 2, Groups F,G | Class III | Type 3R, 4, 4X | IP66/67 | Simultaneous Exposure | Suitable for Use in Wet Locations | Marine Outside Type (Salt Water) | American Bureau of Shipping (ABS) Certified | International Dark Sky (IDA) Approved

LED Luminaires | Area / Task | Hazardous Location | NEC / CEC

Contender™ LED Family Tree

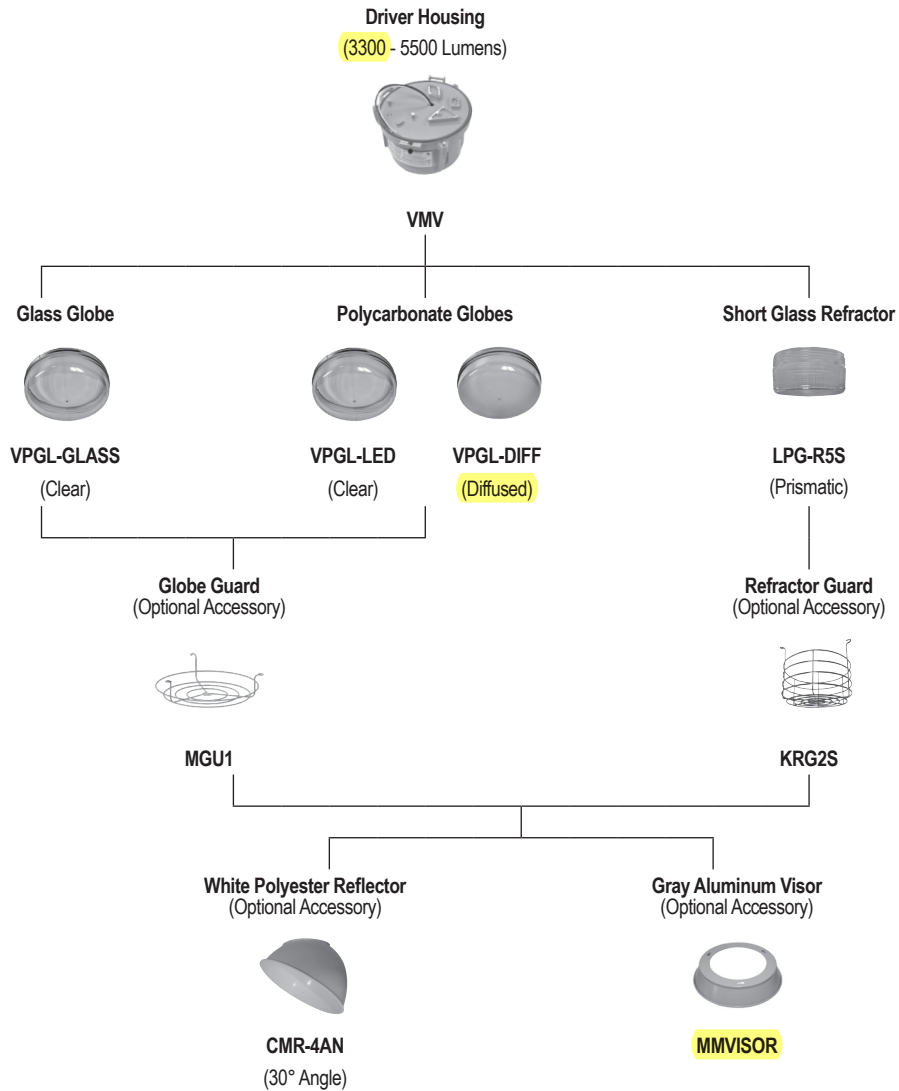

Ⓢ AEx rating is only applicable to product configurations with terminal block wiring option.

Contender™ LED Series Luminaires

Enclosed and Gasketed Fixtures — Hazardous Locations

NEC/CEC: Class I, Division 2, Groups A,B,C,D | Class I, Zone 2, AEx ec IIC ① | Class II, Division 1, Groups E,F,G | Zone 21, AEx tb IIC ① | Class II, Division 2, Groups F,G | Class III | Type 3R, 4, 4X | IP66/67 | Simultaneous Exposure | Suitable for Use in Wet Locations | Marine Outside Type (Salt Water) | American Bureau of Shipping (ABS) Certified | International Dark Sky (IDA) Approved

LED Luminaires | Area / Task | Hazardous Location | NEC / CEC

Order Using Catalog Numbering Guide — Contender™ LED Series Luminaires

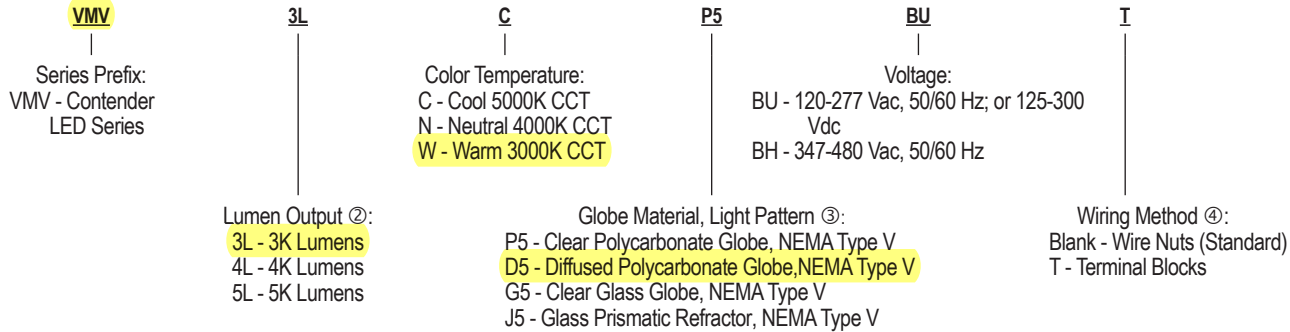

Lumen Output (Efficacy) ⑤

Model	HID Equivalency	Light Distribution Pattern	CCT (Correlated Color Temperature)	CRI (Color Rendering Index)	Lumen Output	Efficacy (lm/W)	CCT	CRI	Lumen Output	Efficacy (lm/W)	CCT	CRI	Lumen Output	Efficacy (lm/W)
Clear Polycarbonate Globe														
VMV3L	70-100W		3000K	>70	3000	107	4000K	>70	3000	107	5000K	>70	3200	114
VMV4L	100-150W	Type V	3000K	>70	3900	102	4000K	>70	4000	105	5000K	>70	4200	110
VMV5L	150-175W		3000K	>70	4900	102	4000K	>70	5000	104	5000K	>70	5300	110
Diffused Polycarbonate Globe ⑥														
VMV3L	70-100W		3000K	>70	2900	103	4000K	>70	2900	103	5000K	>70	3100	110
VMV4L	100-150W	Type V	3000K	>70	3800	100	4000K	>70	3900	102	5000K	>70	4100	107
VMV5L	150-175W		3000K	>70	4800	100	4000K	>70	4900	102	5000K	>70	5150	107
Clear Glass Globe														
VMV3L	70-100W		3000K	>70	3100	110	4000K	>70	3100	110	5000K	>70	3300	117
VMV4L	100-150W	Type V	3000K	>70	4100	107	4000K	>70	4200	110	5000K	>70	4400	115
VMV5L	150-175W		3000K	>70	5100	106	4000K	>70	5200	108	5000K	>70	5500	114
Glass Prismatic Refractor														
VMV3L	70-100W		3000K	>70	2800	100	4000K	>70	2800	100	5000K	>70	3000	107
VMV4L	100-150W	Type V	3000K	>70	3700	97	4000K	>70	3800	100	5000K	>70	4000	105
VMV5L	150-175W		3000K	>70	4600	96	4000K	>70	4650	97	5000K	>70	4900	102

① AEx rating is only applicable to product configurations with terminal block wiring option.

② For specific lumen output information, see Lumen Output table.

③ Guards for the glass refractor and globes are ordered separately. See the Accessories section for more information.

④ Terminal block wiring option is only available with BU voltage configuration.

⑤ All lumen values are typical (tolerance +/- 10%).

⑥ 70 minimum.

Contender™ LED Series Luminaires

Enclosed and Gasketed Fixtures — Hazardous Locations

NEC/CEC: Class I, Division 2, Groups A,B,C,D | Class I, Zone 2, AEx ec IIC ① | Class II, Division 1, Groups E,F,G | Zone 21, AEx tb IIC ① | Class II, Division 2, Groups F,G | Class III | Type 3R, 4, 4X | IP66/67 | Simultaneous Exposure | Suitable for Use in Wet Locations | Marine Outside Type (Salt Water) | American Bureau of Shipping (ABS) Certified | International Dark Sky (IDA) Approved

LED Luminaires | Area / Task | Hazardous Location | NEC / CEC

Electrical Specifications ②

Model	Voltage	Input Power (Watts)	Input Current (Amps)	Power Factor (PF)	Total Harmonic Distortion (THD)
VMV3L	120 Vac	28.0	.28	> .94	< 20%
	277 Vac	28.0	.13		
	125 Vdc	27.2	.24	—	
	300 Vdc	27.2	.09		
	347 Vac	29.7	.10		
VMV4L	480 Vac	29.8	.06	> .93	
	120 Vac	38.0	.38	> .96	< 20%
	277 Vac	38.0	.16		
	125 Vdc	37.4	.32	—	
	300 Vdc	39.0	.13		
347 Vac	39.6	.13			
VMV5L	480 Vac	39.7	.08	> .96	
	120 Vac	48.0	.48	> .97	< 20%
	277 Vac	48.0	.20		
	125 Vdc	50.2	.40	—	
	300 Vdc	48.0	.16		
347 Vac	50.5	.16			
	480 Vac	50.4	.10	> .97	

NEC/CEC Temperature Codes

Model	Max Driver Current (mA)	Max Ambient C° (F°)	Gas		Dust			Gas/Dust
			Class I, Division 2 Groups A, B, C, D ③	Class I, Zone 2 Group AEx ec IIC	Class II, Division 1, Groups E, F, G ④	Zone 20, Group IIC,	Zone 21, AEx tb IIC	Simultaneous ③ Class I, Division 2 / Class II, Division 1
VMV3L	40 (104)	T4A	T4	T6	T6	T85°C	T4A	T5
	55 (131)	T4	T4	T6	T6	T85°C	T4	T4
	65 (149)	T4	T4	T5	T5	T100°C	T4	T4
VMV4L	40 (104)	T4A	T4	T6	T6	T85°C	T4A	T4
	55 (131)	T4	T4	T6	T6	T85°C	T4	T3
	65 (149)	T4	T4	T5	T5	T100°C	T4	T3
VMV5L	40 (104)	T4A	T4	T6	T6	T85°C	T4A	T3
	55 (131)	T4	T4	T6	T6	T85°C	T4	T3
	65 (149)	T4	T4	T5	T5	T100°C	T4	T3

NEC/CEC — “T” Numbers Represent the Maximum Internal Temperature or Maximum Surface Temperature ③ ④

“T” #	T1	350	325	T2	T2A	T2B	T2C	T2D	T3	T3A	T3B	T3C	T4	T4A	T5	T6
Temp. Range °C (°F)	+351 to +450 (+664 to +842)	+326 to +350 (+619 to +662)	+301 to +325 (+574 to +617)	+281 to +300 (+538 to +572)	+261 to +280 (+502 to +536)	+231 to +260 (+448 to +500)	+216 to +230 (+421 to +446)	+201 to +215 (+394 to +419)	+181 to +200 (+358 to +392)	+166 to +180 (+331 to +356)	+161 to +165 (+322 to +329)	+136 to +160 (+277 to +320)	+121 to +135 (+250 to +275)	+101 to +120 (+214 to +248)	+86 to +100 (+187 to +212)	+85 (+185)

Supply Wire Temperature for all: +90 °C (+194 °F).

① AEx rating is only applicable to product configurations with terminal block wiring option.

② All values are typical (tolerance +/-10%).

③ T numbers represent the maximum internal temperature for Class I, Division 2 and Class I, Zone 2 locations designated by the NEC.

④ T numbers represent the maximum surface temperature under a dust blanket for Class II, Division 1 as designated by the NEC.

Contender™ LED Series Luminaires

Enclosed and Gasketed Fixtures — Hazardous Locations

NEC/CEC: Class I, Division 2, Groups A,B,C,D | Class I, Zone 2, AEx ec IIC Ⓢ | Class II, Division 1, Groups E,F,G | Zone 21, AEx tb IIC Ⓢ | Class II, Division 2, Groups F,G | Class III | Type 3R, 4, 4X | IP66/67 | Simultaneous Exposure | Suitable for Use in Wet Locations | Marine Outside Type (Salt Water) | American Bureau of Shipping (ABS) Certified | International Dark Sky (IDA) Approved





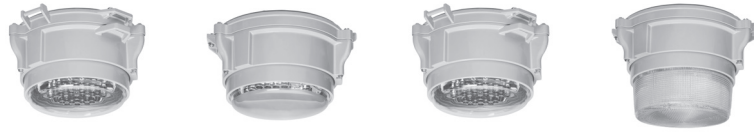



LED Luminaires | Area / Task | Hazardous Location | NEC / CEC

Fixture Unit — Driver Housing and Globe or Refractor

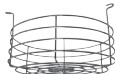

Lumen Level	LED Wattage	Light Level Equivalent	NEMA Type	Catalog Number			
				Polycarbonate Clear Globe ②③④	Polycarbonate Diffused Globe ②③④	Glass Globe ②③④	With Type V Glass Refractor ②③④
Driver Housing							
3K	28	70-100W HPS	Type V	VMV3LCP5	VMV3LCD5	VMV3LCG5	VMV3LCJ5
4K	38	100-150W HPS	Type V	VMV4LCP5	VMV4LCD5	VMV4LCG5	VMV4LCJ5
5K	48	150-175W HPS	Type V	VMV5LCP5	VMV5LCD5	VMV5LCG5	VMV5LCJ5

Accessories and Replacement Parts

	Description	Weight in kg (lbs)	Catalog Number
Globes			
	Clear Globe — Polycarbonate	0.2 (0.5)	VPGL-LED
	Diffused Globe — Polycarbonate	0.2 (0.5)	VPGL-DIFF
	Clear Globe — Glass	0.9 (1.9)	VPGL-GLASS
Light Distribution			
Prismatic Glass Refractor — All Heat-Resistant			
	Short Prismatic Glass Refractor — NEMA Type V	1.7 (3.7)	LPG-R5S
Guards			
	Globe Guard	0.2 (0.4)	MGU1
	Short Refractor Guard for LPG-R5S	0.3 (0.7)	KRG2S
Reflector			
	30° Angle White Polyester Reflectors	1.3 (2.7)	CMR-4AN
Visor			
	Electrostatically applied gray epoxy powder coat finish on Aluminum Visor	0.4 (0.9)	MMVISOR
Safety Cable			
	Stainless steel	0.2 (0.4)	LEDSC

① AEx rating is only applicable to product configurations with terminal block wiring option

② For 120-277 Vac, use suffix **-BU**. For 347-480 Vac, use suffix **-BH**.

③ Guards are available for fixtures with glass globe or refractor. See Accessories and Replacement Parts table for ordering information.

④ Correlated Color Temperature (CCT) indicated by C, N or W; C = Cool, 5000K CCT, N = Neutral, 4000K CCT, W = Warm, 3000K CCT. Example: **VMV5LCD5BU**.

Contender™ LED Series Luminaires

Enclosed and Gasketed Fixtures — Hazardous Locations

NEC/CEC: Class I, Division 2, Groups A,B,C,D | Class I, Zone 2, AEx ec IIC Ⓢ | Class II, Division 1, Groups E,F,G | Zone 21, AEx tb IIC Ⓢ | Class II, Division 2, Groups F,G | Class III | Type 3R, 4, 4X | IP66/67 | Simultaneous Exposure | Suitable for Use in Wet Locations | Marine Outside Type (Salt Water) | American Bureau of Shipping (ABS) Certified | International Dark Sky (IDA) Approved

Replacement Drivers

	Model	Voltage	Driver Wattage	Constant Current Settings	Catalog Number
	VMV3L	BU	50 Watt	720mA	APMS050C135UD72
		BH		720mA	APMS050C135HD72
	VMV4L	BU	50 Watt	1000mA	APMS050C135UD10
		BH		1000mA	APMS050C135HD10
	VMV5L	BU	50 Watt	1300mA	APMS050C135UD13
		BH		1300mA	APMS050C135HD13

Luminaire Weights

Description	Weight kg (lb)
Fixture Unit with Polycarbonate Clear Globe	5.3 (11.8)
Fixture Unit with Polycarbonate Diffused Globe	5.3 (11.8)
Fixture Unit with Polycarbonate Glass Globe	5.9 (13.0)
Fixture Unit with Short Prismatic Glass Refractor	6.7 (14.9)

Dimensions in Millimeters (Inches)

Clear/Diffused/Glass Globes

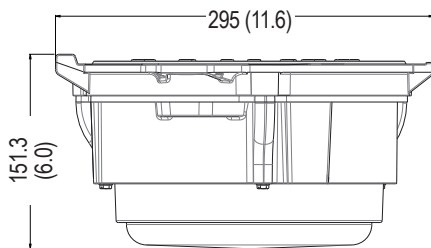

Short Prismatic Glass Refractor

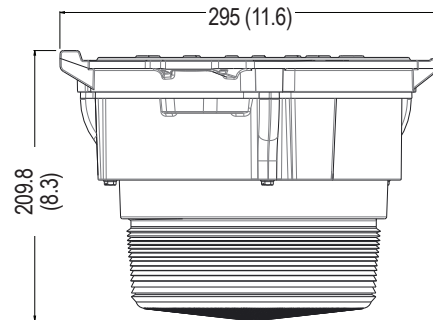

Ⓢ AEx rating is only applicable to product configurations with terminal block wiring option

IES ROAD REPORT

PHOTOMETRIC FILENAME : VMV3LWD5BU_2018-MAR-10_PRODUCTION_REV01 FOR ROADWAY REPORT.IES

ISOFOOTCANDLE LINES OF HORIZONTAL ILLUMINANCE

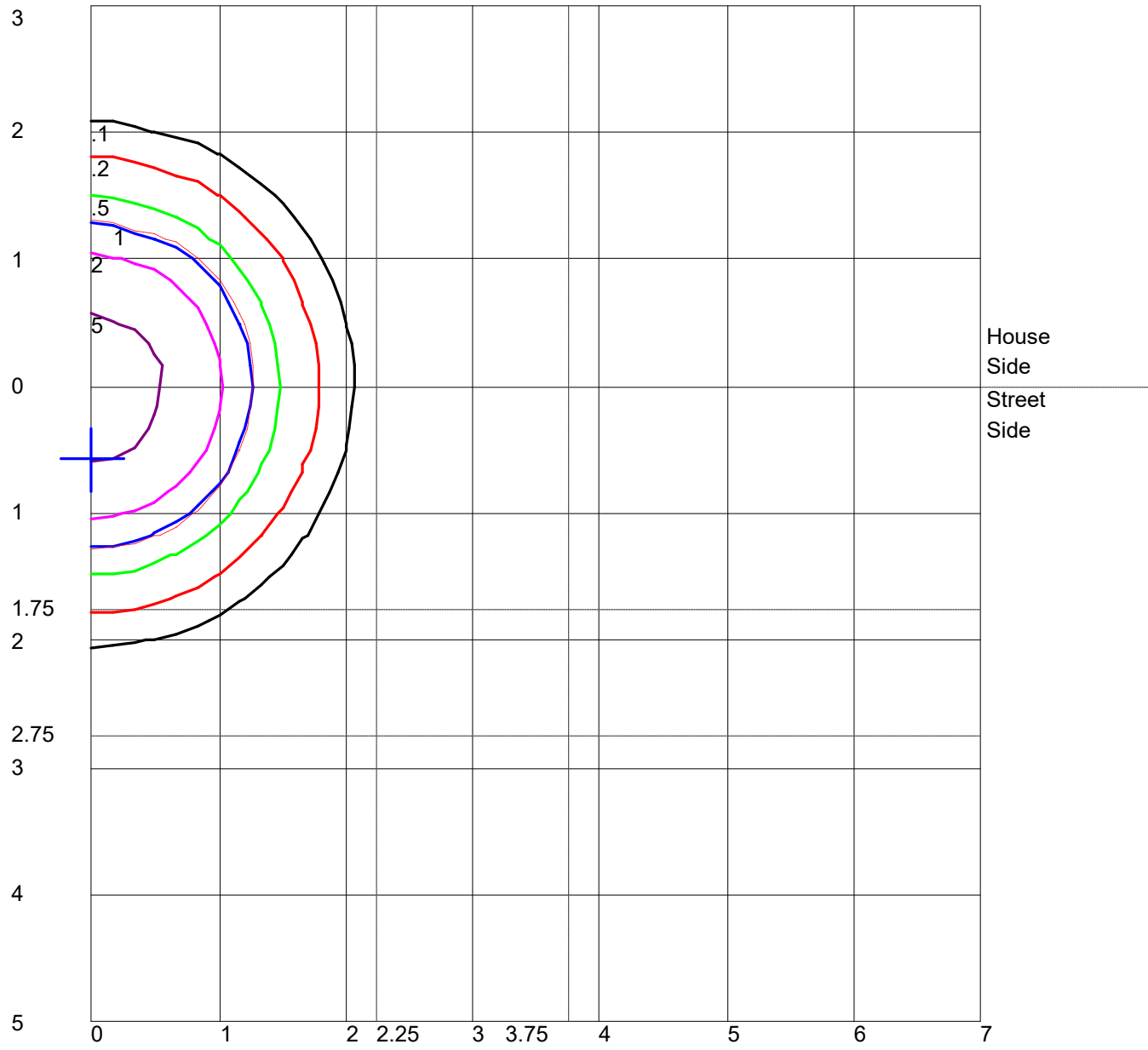

Distance In Units Of Mounting Height
Values Based On 12 Foot Mounting Height
1/2 Maximum Candela Trace Shown As Dashed Curve
(+) = Maximum Candela Point

LUMINAIRE CLASSIFICATION SYSTEM (LCS) GRAPH

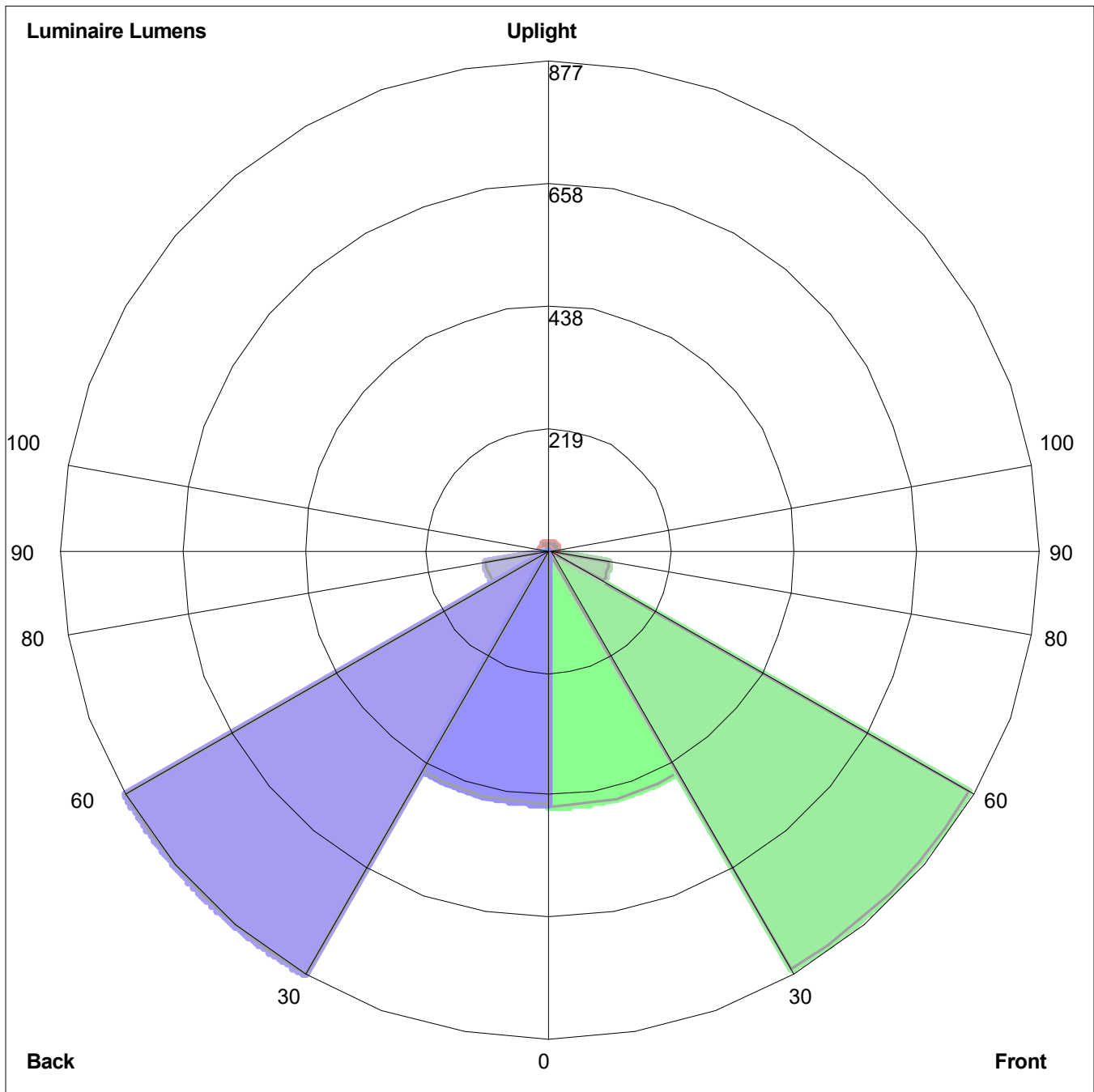

Luminaire Lumens:
Front: Low=459.2, Medium=865.9, High=109.8, Very High=9.0
Back: Low=454.4, Medium=876.9, High=116.1, Very High=9.9
Uplight: Low=7.6, High=14.0

BUG Rating : B1-U2-G0